



December 8, 2020, WMO VCP Workshop, Hong Kong (Online)

Outline and recent development of mesoscale NWP system in JMA

Masaru Kunii

Numerical Prediction Division, Japan Meteorological Agency

mkunii@met.kishou.go.jp

Contents

- Outline of operational NWP system at JMA
- **Forecast model: Meso-Scale Model (MSM)**
 - Focus on the new-generation mesoscale model **ASUCA**, introduced into the operational MSM in February 2017.
- Data assimilation system: Meso-Scale Analysis (MA)
- Meso-Scale Ensemble Prediction System (MEPS)

OUTLINE OF OPERATIONAL MESO-SCALE NWP SYSTEM

Main NWP models at JMA

Global Spectral Model (GSM)

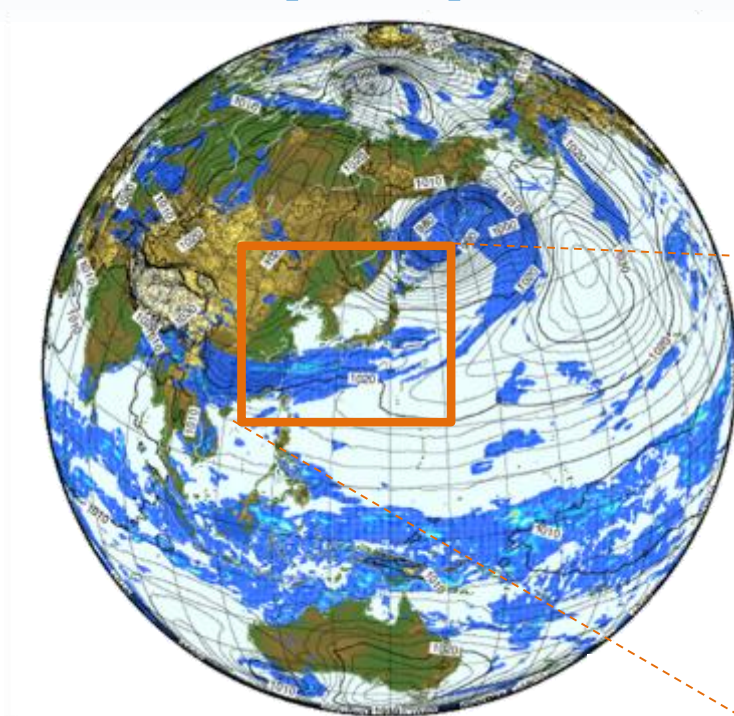

Resolution ~ 20 km

Meso-Scale Model (MSM)

Resolution 5 km

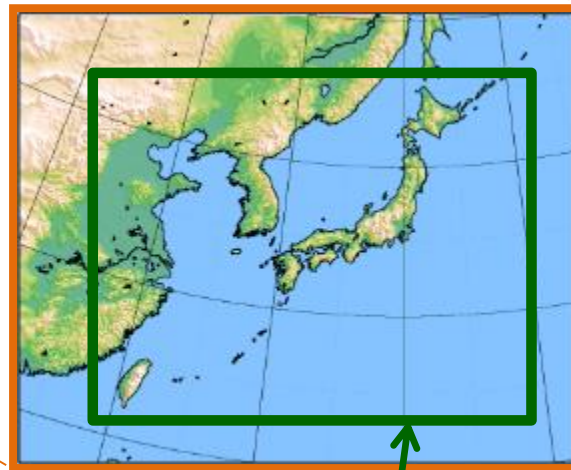



Local Forecast Model (LFM)

Resolution 2 km

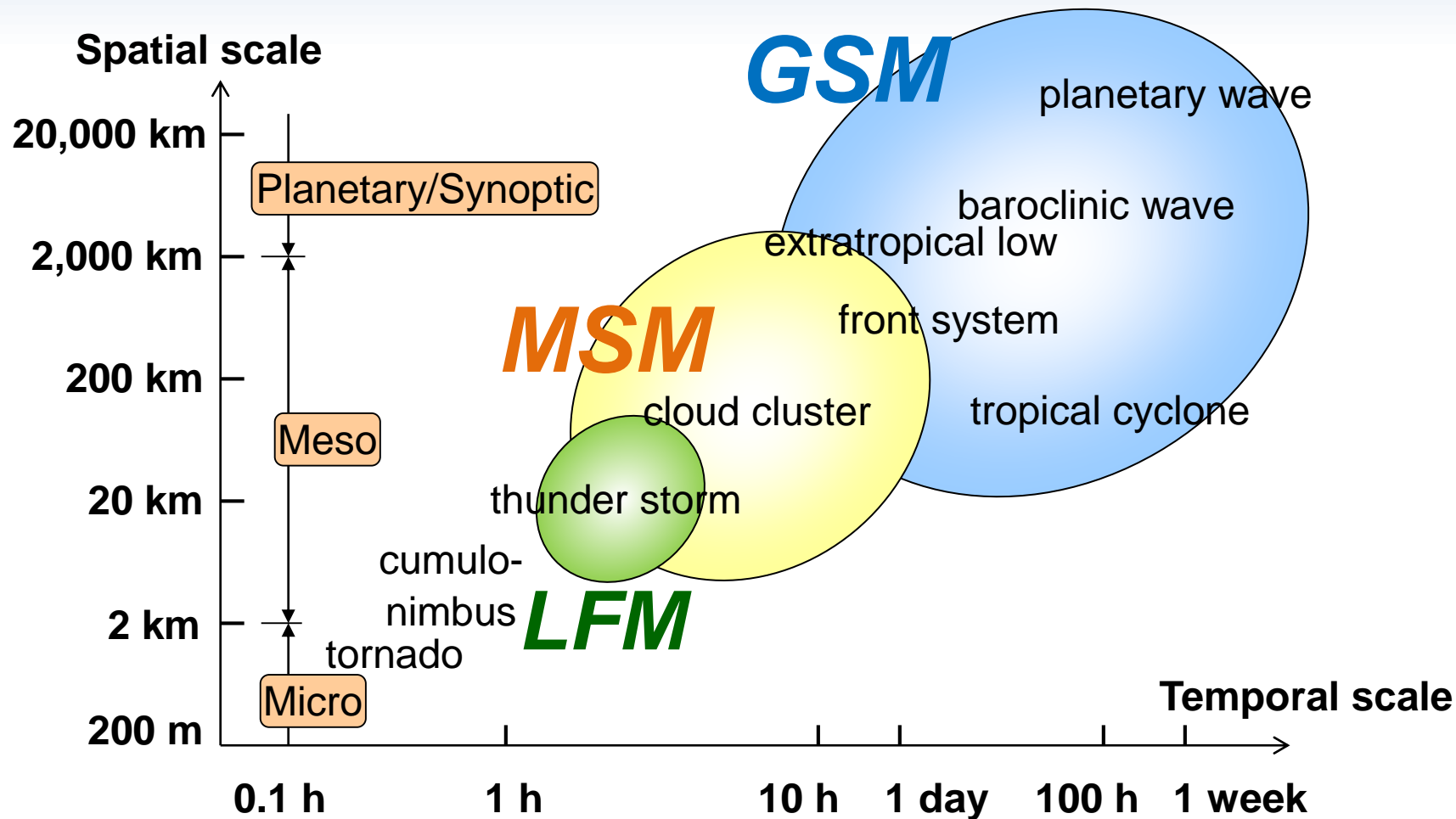
Spatial and temporal scale of atmospheric phenomena

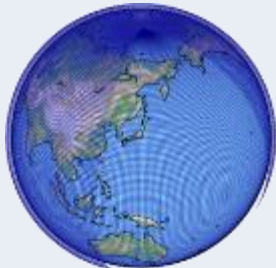
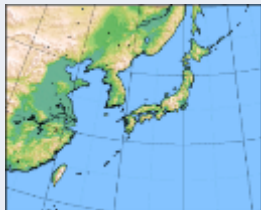

Operational suites of NWP systems at JMA

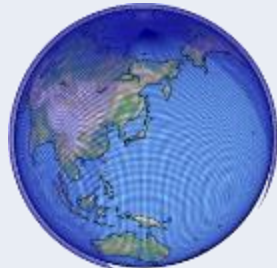
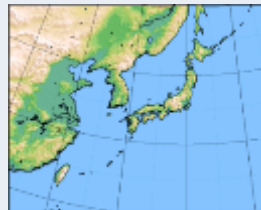
	Global Spectral Model (GSM)	Meso-Scale Model (MSM)	Local Forecast Model (LFM)	Global Ensemble Prediction System (GEPS) ¹	Meso-Scale Ensemble Prediction System (MEPS)
Objectives	Short- and medium-range forecasts	Disaster reduction, aviation forecasts, short-range forecasts	Aviation forecasts, disaster reduction	Typhoon forecasts, one-week forecasts	Disaster reduction, aviation forecasts
Forecast domain	Global 	Japan and its surroundings 	Japan and its surroundings 	Global 	Japan and its surroundings 
Horizontal resolution	TL959 (≈ 20 km)	5 km	2 km	TL479 (≈ 40 km)	5 km
Vertical levels / top	100 / 0.01 hPa	76 / 21.8 km	58 / 20.2 km	100 / 0.01 hPa	76 / 21.8 km
Forecast hours (initial times)	264 hours (12 UTC), 132 hours (00, 06, 18 UTC)	51 hours (00, 12 UTC), 39 hours (03, 06, 09, 15, 18, 21 UTC)	10 hours (00–23 UTC hourly)	264 hours (00, 12 UTC), 132 hours (06, 18 UTC) ²	39 hours (00, 06, 12, 18 UTC)
Initial conditions	Global analysis (Hybrid 4D-Var)	Meso-scale analysis (4D-Var)	Local analysis (3D-Var)	Global analysis (4D-Var) with ensemble perturbations (SV, LETKF)	Meso-scale analysis with ensemble perturbations (SV)
Ensemble members	—	—	—	27	21 (Control = MSM)

¹ Only the specifications of typhoon forecasts and one-week forecasts

² Only when a TC of TS intensity or higher is present or expected in the RSMC Tokyo–Typhoon Center’s area of responsibility (0°–60°N, 100°E–180°)

Objectives of meso-scale NWP system

- **Disaster prevention**
 - Prediction of severe weather (heavy rainfall etc.) is important to reduce loss of life and property
 - Input to very short-range precipitation forecast system
 - Input to storm surge model
- **Aviation forecasts**
 - Enhanced weather information for aviation safety
 - Terminal Aerodrome Forecast (TAF) guidance and so on
- **Short-range forecasts**
 - Weather forecasts for two days

Meso-scale NWP system

- Forecast Model: Meso-Scale Model (MSM) based on nonhydrostatic forecast model **ASUCA**
- Data Assimilation System: Meso-Scale Analysis (MA) based on nonhydrostatic meso 4DVar-system (**asuca-Var**)

Domain

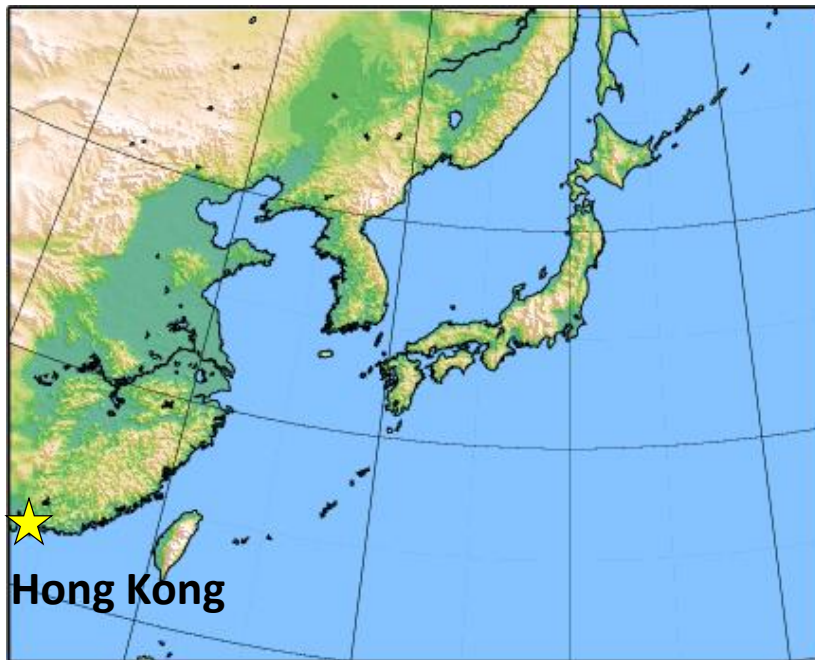

Specifications

- Horizontal grid spacing: 5 km
- Domain: 4080 x 3300 km
(817 x 661 grid points)
- Forecast time:
51 hours (00, 12 UTC)
39 hours (03, 06, 09, 15, 18 21 UTC)
- Forecast model:
Meso-Scale Model (MSM)
- Initial condition (atmosphere):
Meso-Scale Analysis (MA)
- Boundary condition:
20km-GSM (Global Spectral Model)

Data flow of daily NWP

- Iteration of analysis (data assimilation) and forecast
- Initial condition: generated by modifying a previous model forecast using newly received observations

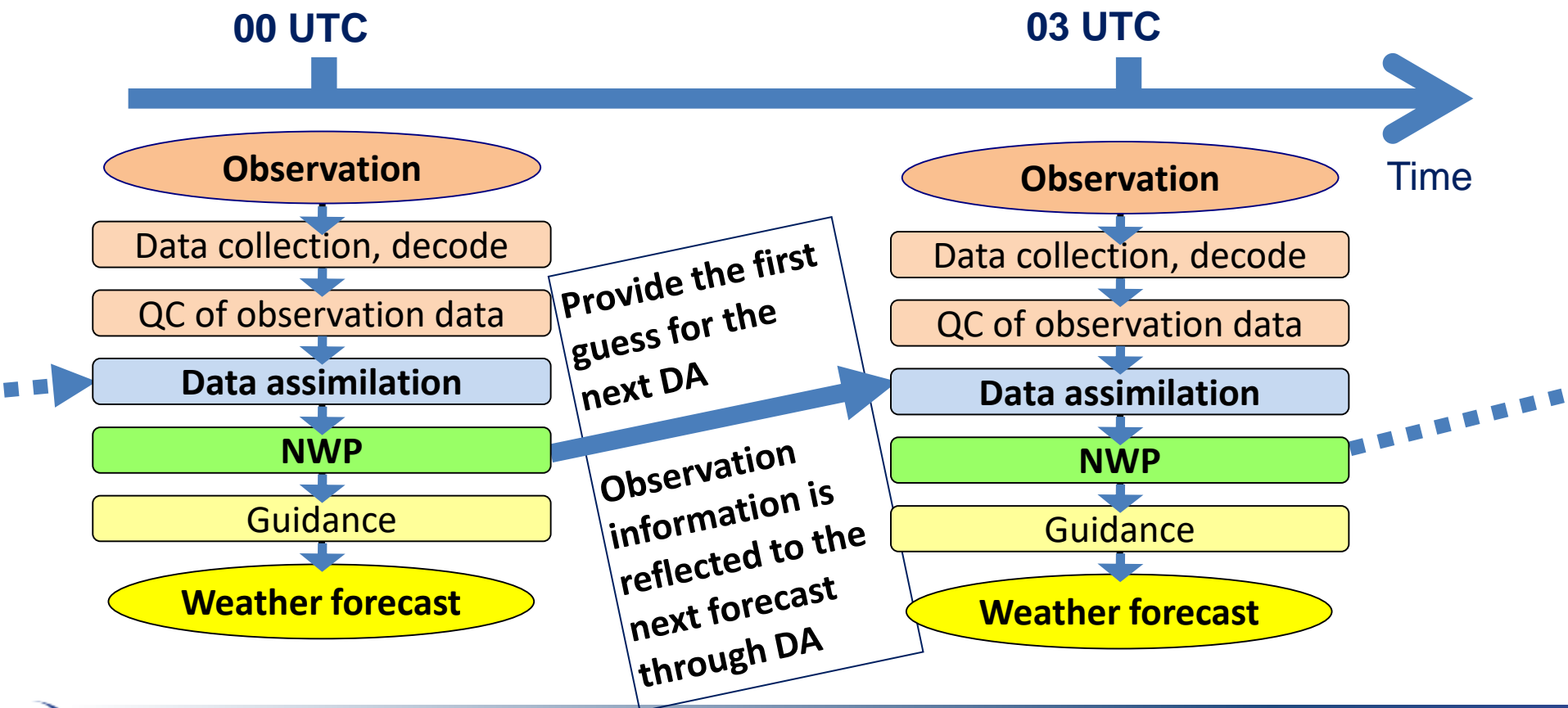

FORECAST MODEL: MESO-SCALE MODEL (MSM)

Achievements in a nutshell

- **March 2001**
 - Newly introduced with a hydrostatic spectral model ($\Delta x = 10$ km), running 4 times per day up to 18 hours.
- **September 2004**
 - Replaced with a **non-hydrostatic grid model** (JMA-NHM, Saito et al. 2006, 2007).
- **March 2006**
 - Enhanced resolutions ($\Delta x = 5$ km) and operation frequency (8 times per day).
- **May 2013**
 - Extended forecast period up to 39 hours with an enlarged domain.
- **February 2017**
 - Upgrade to a **new-generation JMA nonhydrostatic model** (ASUCA, Ishida et al. 2009, 2010).
- **March 2020**
 - Mesoscale data assimilation system was replaced with the ASUCA-based 4DVar.

asuca: **A**suca is a **S**ystem based on a **U**nified **C**oncept for **A**tmosphere

JMA-NHM

- **JMA-NHM** has been developed since 1980's.
 - Operational Meso-scale model from 2004 to 2017
 - Widely used as **a community NWP model** in not only domestic but also foreign research communities
 - Matured but old technics at this time
 - **Insufficient accuracy** such as **no mass conservation**, leap-frog scheme with time filter
 - **Artificial parameters** are used as keys for **computational stability**
 - Forecasts are quite sensitive to these parameters
 - Not necessarily compatible with **the current computer trend**
 - Almost no room left for further developing
 - Fairly convoluted codes
 - Codes for physics cannot be separated

Motivation for a new dynamical core

- A new nonhydrostatic dynamical core named “**ASUCA**” is developed aiming at
 1. Higher **accuracy, stability**
e.g. exact conservation of mass
 2. Exclusion of artificial parameters (e.g. **numerical diffusion coefficient**) as much as possible
 3. **Higher efficiency** on **massive parallel scalar multi-core architecture**
 4. Keeping the codes as modular as possible to facilitate the developments and long term maintenance
- ASUCA successfully went into operation as MSM (and LFM), replacing its predecessor JMA-NHM

Implementation of ASUCA

- Flux-form fully compressible governing equations with the finite volume method
 - **Guarantee mass conservation**
- Three-stage Runge-Kutta scheme for time integration
 - **Better computational stability** even with a longer time-step interval
- Improvement of parallelization and coding methods
 - **More effective computation** on massive scalar multi-core architecture
- Physical processes are implemented via the use of the “Physics Library”
 - Various subroutines related to physical processes are collected as vertical one-dimensional models with unified coding and interface rules

Governing equations of ASUCA

(x_1, x_2, x_3) : physical space.
 ($\hat{x}_1, \hat{x}_2, \hat{x}_3$) : computational space.

$$\frac{\partial}{\partial t} \left(\frac{\rho u^i}{J} \right) + \frac{\partial}{\partial \hat{x}^n} \left(\frac{\rho u^i \hat{u}^n}{J} \right) + \frac{\partial}{\partial \hat{x}^n} \left(\frac{1}{J} \frac{\partial \hat{x}^n}{\partial x^i} p' \right) - \frac{\rho' \delta^i_{3g}}{J} = \frac{F^i}{J},$$

$$\frac{\partial}{\partial t} \left(\frac{\rho'}{J} \right) + \frac{\partial}{\partial \hat{x}^n} \left(\frac{\rho \hat{u}^n}{J} \right) = \frac{F_\rho}{J},$$

Density is used as the prognostic variable for **mass conservation**

$$\frac{\partial}{\partial t} \left(\frac{(\rho \theta_m)'}{J} \right) + \frac{\partial}{\partial \hat{x}^n} \left(\frac{\rho \theta_m \hat{u}^n}{J} \right) = \frac{F_{\rho \theta_m}}{J},$$

J is a Jacobian of the coordinate transformation

u, v, w : velocity components in the physical space

$\hat{u}, \hat{v}, \hat{w}$: those in the computational space

ρ : total mass density

$$\frac{\partial}{\partial t} \left(\frac{\rho q_\alpha}{J} \right) + \frac{\partial}{\partial \hat{x}^n} \left(\frac{\rho q_\alpha \hat{u}_\alpha^n}{J} \right) = \frac{F_{\rho q_{\alpha m}}}{J}, \quad \alpha = v, c, r, i, s, g, h,$$

q_α : ratio of the density of a water substance α to the total mass density

$$\pi = \left(\frac{p}{p_0} \right)^{\frac{R_d}{C_p}}, \quad p = R_d \pi(\rho \theta_m), \quad \theta_m = \theta \left(1 + (\varepsilon - 1) q_v + \sum_{\alpha \neq v} q_\alpha \right),$$

$$p' = \frac{C_p}{C_v} R_d \pi(\rho \theta_m) - \bar{p}.$$

Note: Perturbations (ρ' , $\rho \theta_m'$) from reference state used as prognostic variables

- The RHS terms involve not only physics processes, Coriolis terms and curvature terms but also the terms arising from change of density due to precipitation and physical processes.

Finite Volume Method

The computational domain is divided into cells.
Fluxes at cell boundaries are evaluated.

$$\frac{\partial \rho}{\partial t} + \nabla \cdot (\rho \mathbf{u}) = 0$$

$$\frac{\partial}{\partial t} \int \rho dV + \oint \rho \mathbf{u} \cdot d\mathbf{S} = 0$$

Continuous equation with differential form (left)
and integral form (right)

The surface integral of the equation in the integral form is approximated by sum of the flux at boundaries

- **Conservative**
- Suitable for unstructured meshes

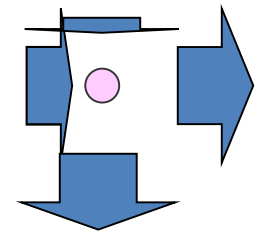

Three-stage Runge-Kutta scheme

$$\begin{aligned}\phi^* &= \phi_t + F(\phi_t) \frac{1}{3} \Delta t \\ \phi^{**} &= \phi_t + F(\phi^*) \frac{1}{2} \Delta t \\ \phi_{t+\Delta t} &= \phi_t + F(\phi^{**}) \Delta t\end{aligned}$$

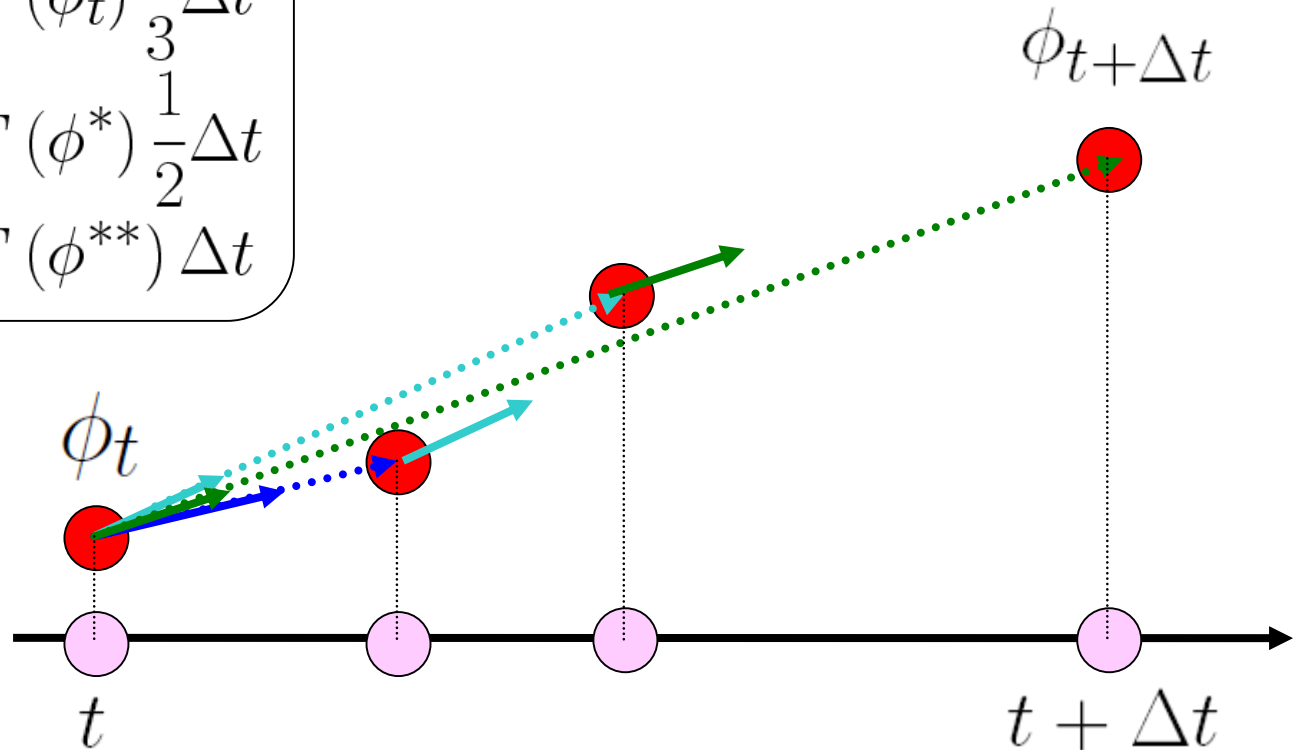

Time step interval may be extended to twice of that of leap-frog
(Leap-frog was implemented in JMA-NHM)

Specifications of Dynamical Core

	ASUCA	JMA-NHM
Governing equations	Flux form Fully compressible equations	Quasi flux form Fully compressible equations
Prognostic variables	$\rho u, \rho v, \rho w, \rho \theta_m, \rho$	$\rho u, \rho v, \rho w, \theta, p$
Spatial discretization	Finite volume method	Finite difference Method
Time integration	Runge-Kutta 3 rd (long and short)	Leapflog with time filter (long) Forward backward (short)
Treatment of sound	Conservative Split explicit	Split explicit
Advection	Combining 3 rd and 1 st order upwind with flux limiter by Koren(1993)	4 th (hor.) and 2 nd (ver.) order with advection correction
Numerical diffusion	None	4 th order linear and nonlinear diffusion
Treatment of rain-drop	Time-split	Box-Lagrangian
Coordinate	Generalized coordinate or Conformal mapping + Hybrid-Z	Conformal mapping (hor.) Hybrid-Z (ver.)
Grid	Arakawa-C (hor.) Lorentz (ver.)	Arakawa-C (hor.) Lorentz (ver.)

	ASUCA	JMA-NHM
Time integration	Runge-Kutta 3 rd	Leapflog with time filter
Advection	Combining 3 rd and 1 st order upwind with flux limiter by Koren(1993)	4 th order with advection correction(Kato,1998)
Numerical diffusion	None	4 th order linear and nonlinear diffusion

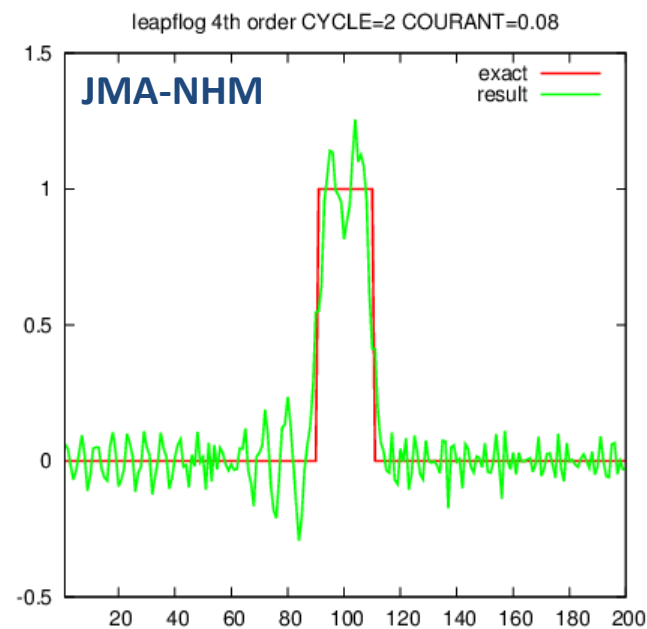
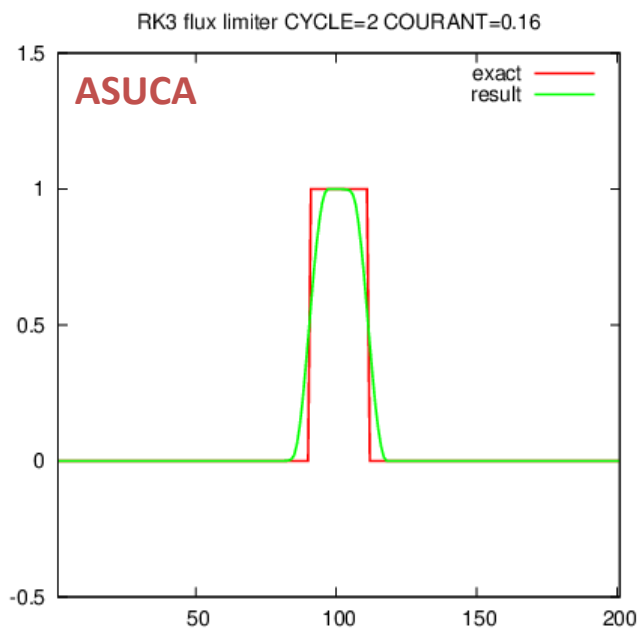

Cycle advection test in a constant velocity field.
Green line is the result of after two cycles (2500 steps with $dt=8s$).

	ASUCA	JMA-NHM
Time integration	Runge-Kutta 3 rd	Leapflog <u>with time filter</u>
Advection	Combining 3 rd and 1 st order upwind with flux limiter by Koren(1993)	4 th order with advection correction(Kato,1998)
Numerical diffusion	None	4 th order linear and nonlinear diffusion

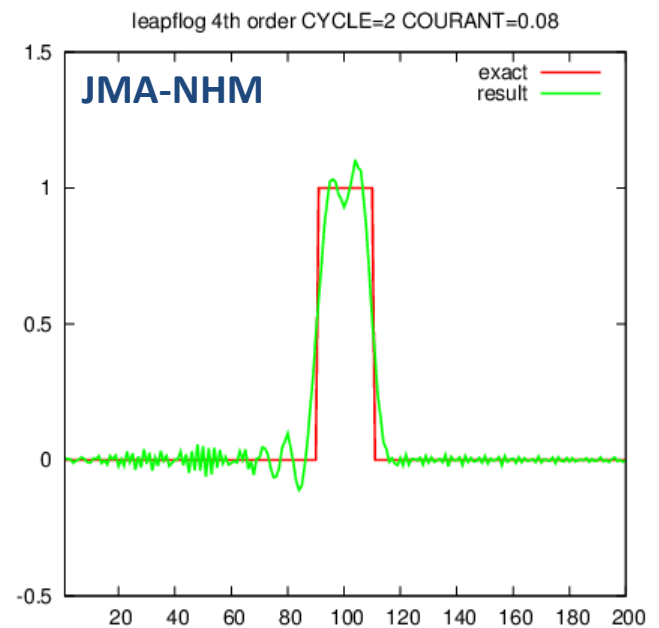
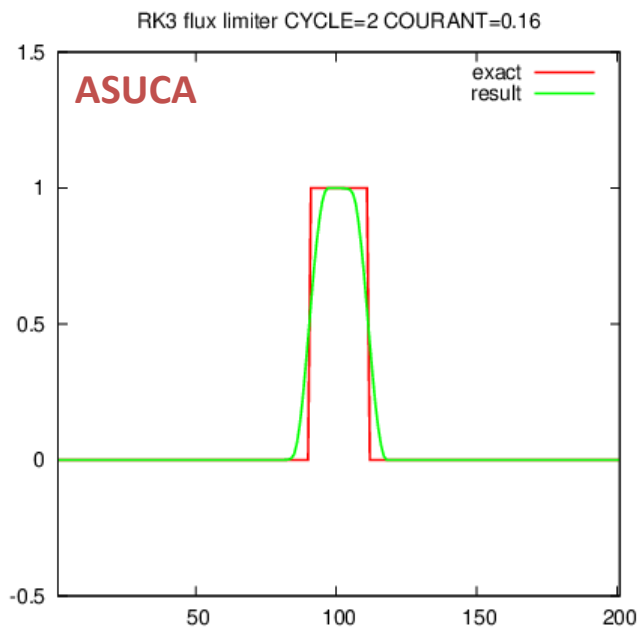

	ASUCA	JMA-NHM
Time integration	Runge-Kutta 3 rd	Leapflog with time filter
Advection	Combining 3 rd and 1 st order upwind with flux limiter by Koren(1993)	4 th order with advection correction(Kato,1998)
Numerical diffusion	None	4 th order linear and nonlinear diffusion

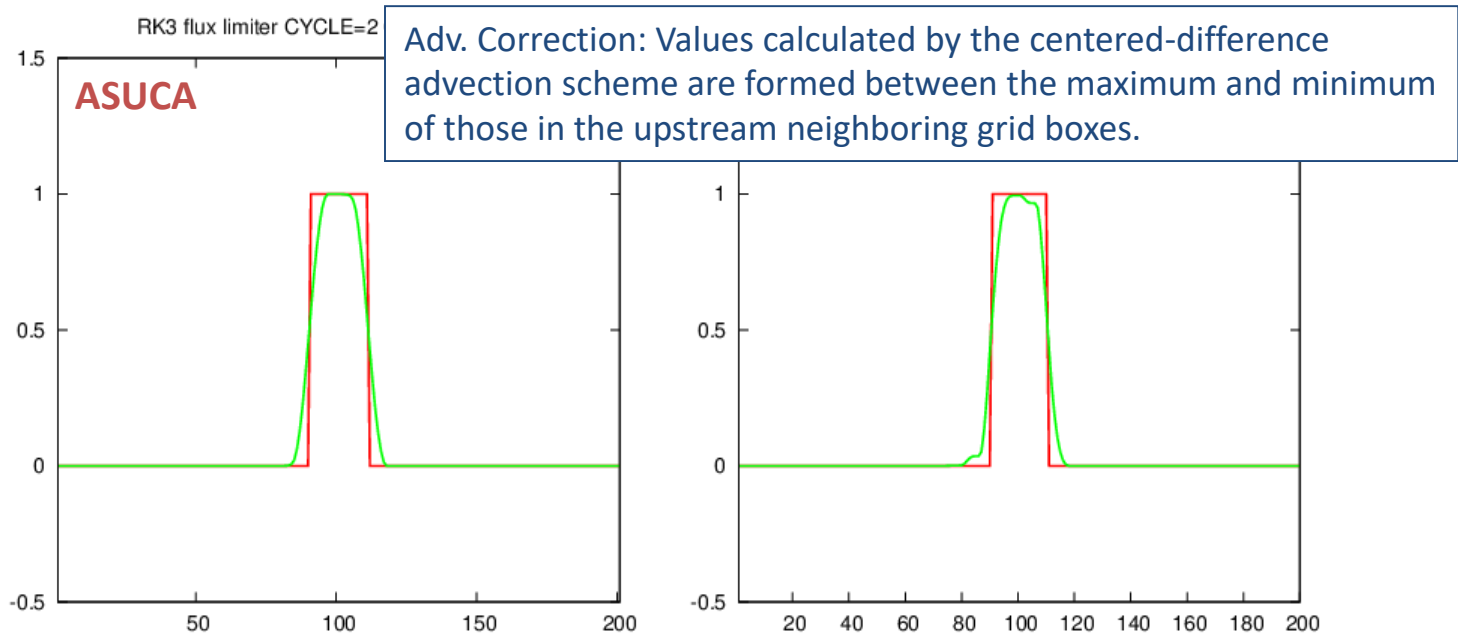

Adding adv.correction requires extra MPI comm. of halo region

	ASUCA	JMA-NHM
Time integration	Runge-Kutta 3 rd	Leapflog with time filter
Advection	Combining 3 rd and 1 st order upwind with flux limiter by Koren(1993)	4 th order with advection correction(Kato,1998)
Numerical diffusion	None	4 th order linear and nonlinear diffusion

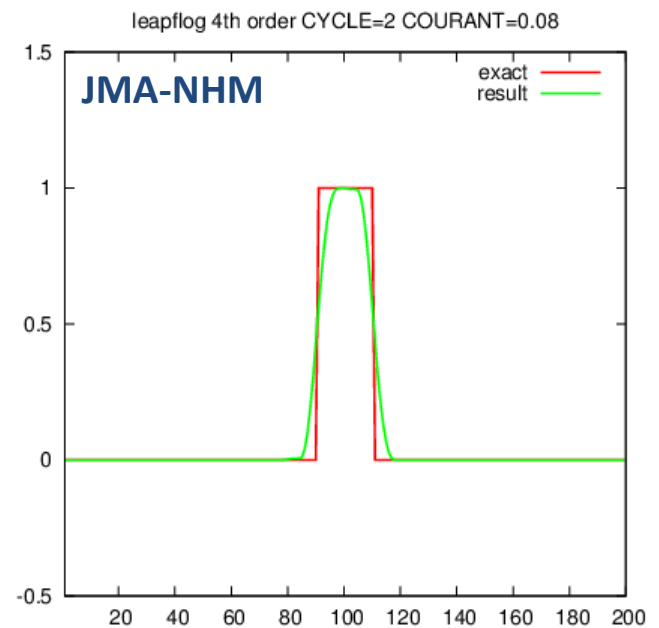
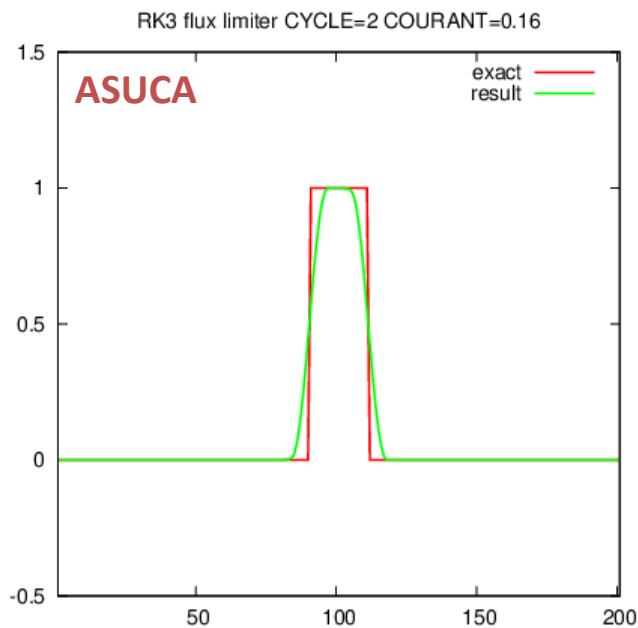

	ASUCA	JMA-NHM
Time integration	Runge-Kutta 3 rd	Leapflog with time filter
Advection	Combining 3 rd and 1 st order upwind with flux limiter by Koren(1993)	4 th order with advection correction(Kato,1998)
Numerical diffusion	None	4 th order linear and <u>nonlinear diffusion</u>

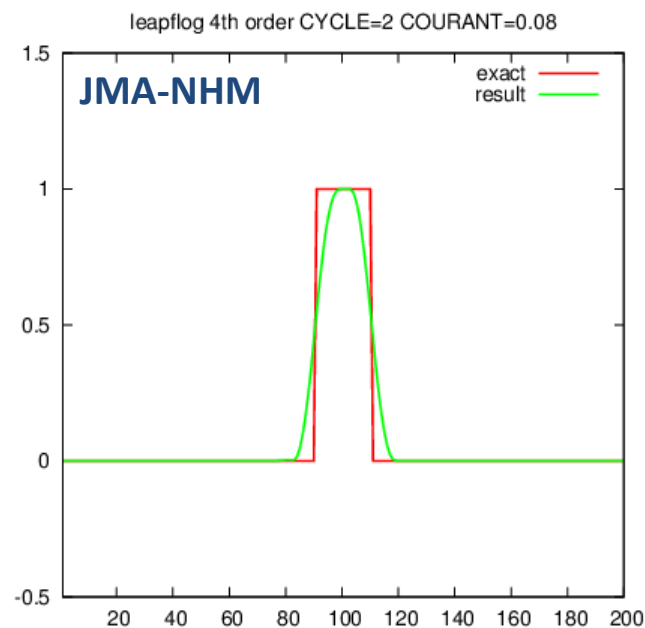
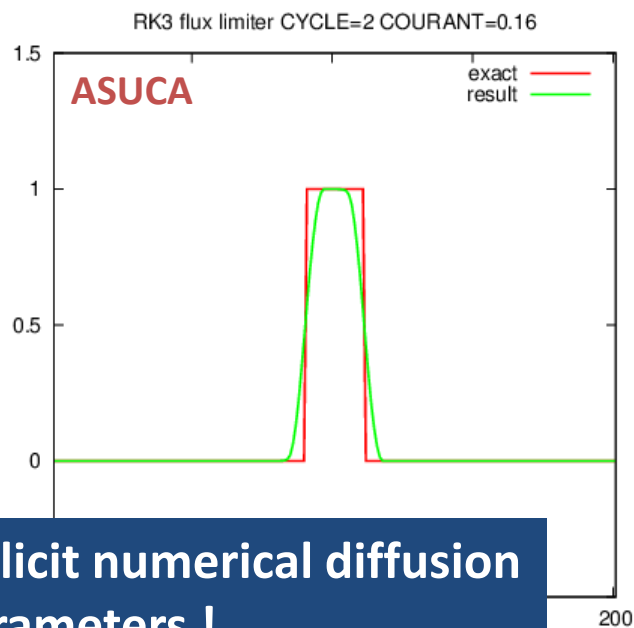

NO NEED for explicit numerical diffusion with artificial parameters !

ASUCA reproduced Karman vortex streets

Initial time at 2015/02/18/00UTC (T+0 to T+9)

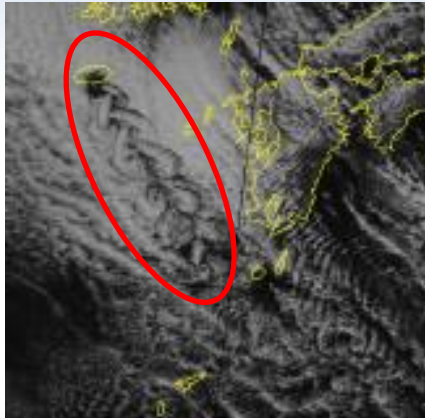

Karman vortex streets on the leeward side of Jeju island are well reproduced by the ASUCA ($\Delta x=2\text{km}$).

Observation at 2015/02/18/04UTC

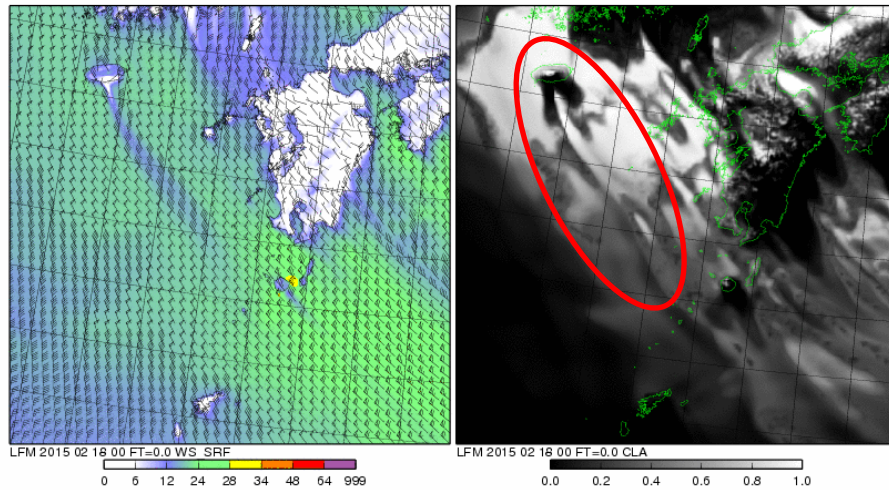

2-km ASUCA

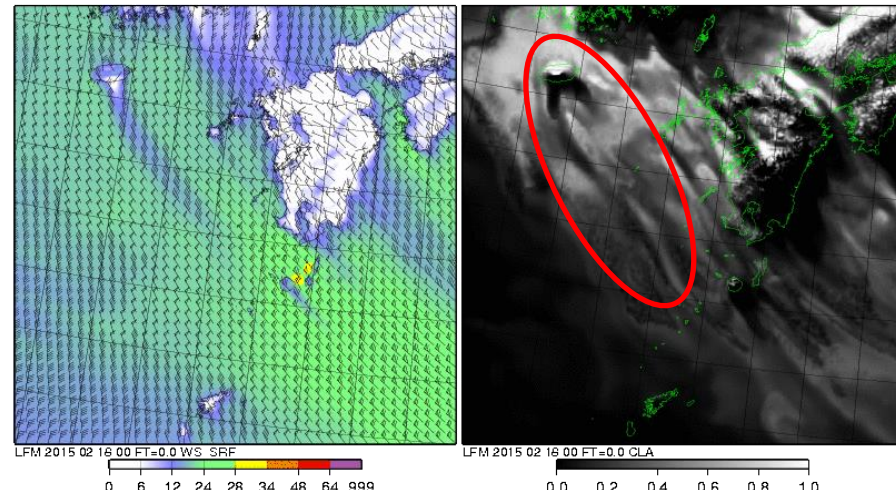

2-km JMA-NHM

Time integration loop of ASUCA

(Simplified from the viewpoint of dynamics-condensation)

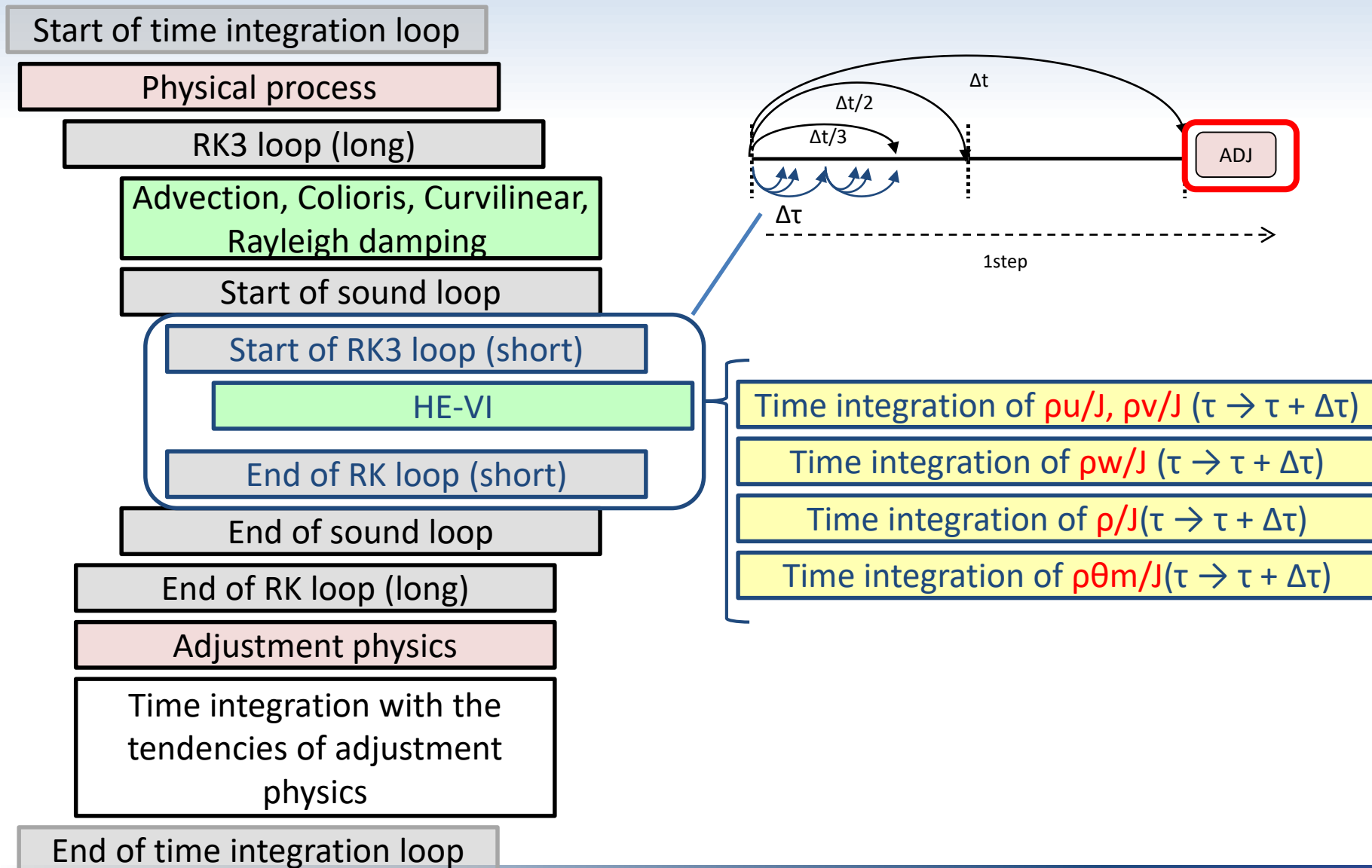

Physical processes

- The pure **ASUCA** consists of only dynamical core
- Physical processes are provided by a separately developed library called “**Physics library**” (Hara et al. 2012)
 - A repository of
 - many physics subroutines
 - test cases to evaluate their performances
 - Provides tendencies to dynamical core
 - designed to be plugged in easily to any models

Structure of the “Physics Library”

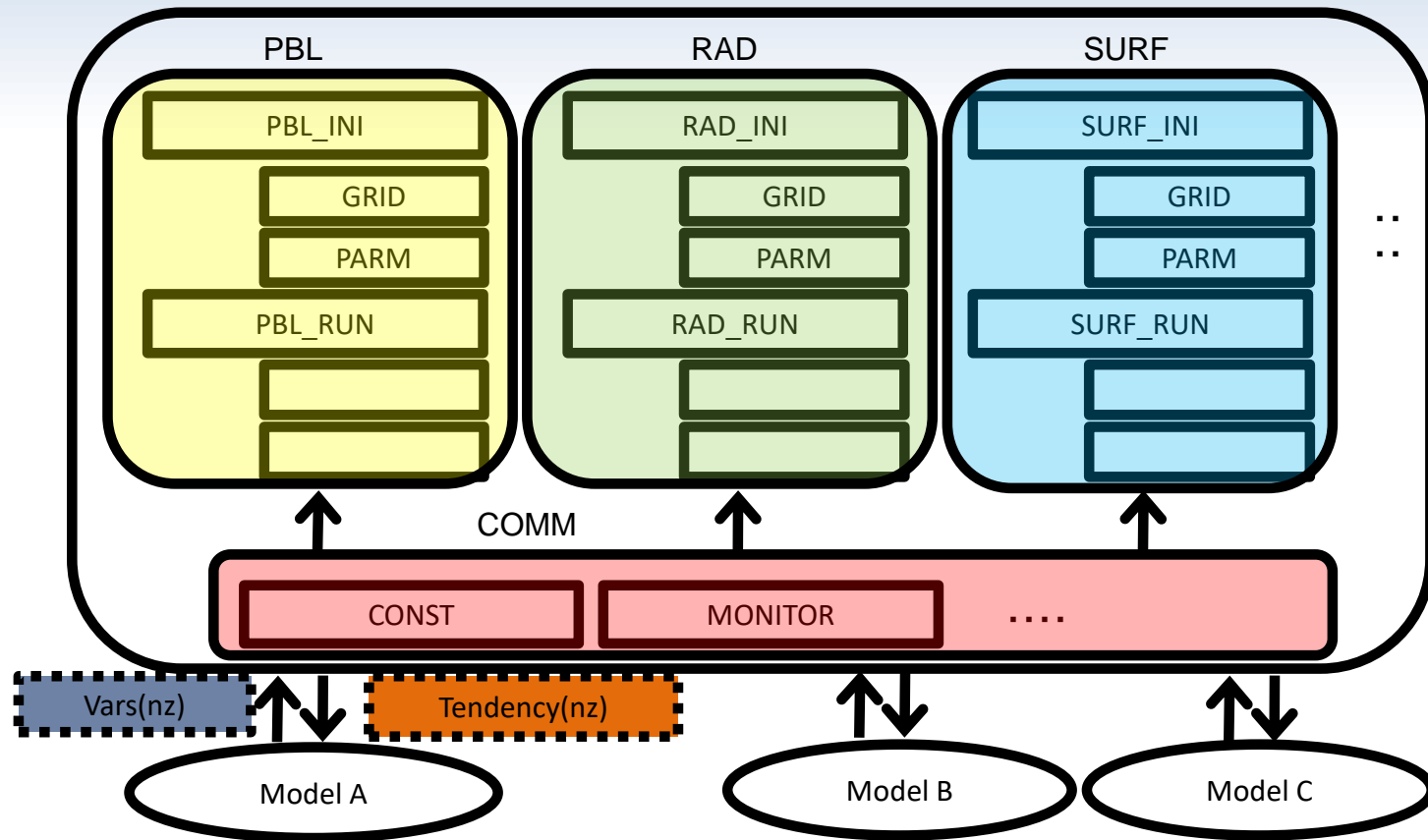

- The “Physics Library” is designed to be plugged in easily to any models
- The physical processes implemented in the “Physics Library” are **vertically one-dimensionalized**.
- ASUCA passes **inputs (Vars(nz))** to library, then receives **tendencies (tendency(nz))** from library.

Implementation of physical processes

- Physical processes are expected to provide tendencies. ASUCA just receives tendencies and temporally integrate with them.
- Column based physical processes include only the vertical one-dimensional loop
- The horizontal loops are parallelized using OpenMP.
- Modularity and high efficiency are satisfied

```
real :: pt(nz,nx,ny), tend_pt(nz,nx,ny)
real :: qv(nz,nx,ny), tend_qv(nz,nx,ny)
real :: pt_1d(nz), tend_pt_1d(nz)

!$OMP PARALLEL DO SCHEDULE(DYNAMIC) &
!$OMP& PRIVATE(pt_1d,tend_pt_1d)
do j = 1, ny
do i = 1, nx
pt_1d(1:nz) = pt(1:nz,i,j)
qv_1d(1:nz) = qv(1:nz,i,j)
call pp_A(i,j,tend_pt_1d,tend_qv_1d,pt_1d,qv_1d,...)
tend_pt(1:nz,i,j) = tend_pt_1d(1:nz)
tend_qv(1:nz,i,j) = tend_qv_1d(1:nz)
end do
end do
!$OMP END PARALLEL DO
```

kij -ordering

real(8) :: pt(nz, nx, ny)

Three-dimensional arrays in space are stored sequentially in the order of z (k), x (i) and y (j).

kij-ordering

- Better load balance among PEs

kij-ordering

- Better cache hit ratio with vertical one dimensional calculation

In practice, physics tendencies are converted to those of ASUCA's prognostic variables

ASUCA improves precipitation forecast

Various upgrades, including improvements in cumulus parameterization and cloud microphysics, contribute to forecasting enhancements, especially in summer precipitation.

Verification of 3h-accumulated precipitation forecasts in summer.

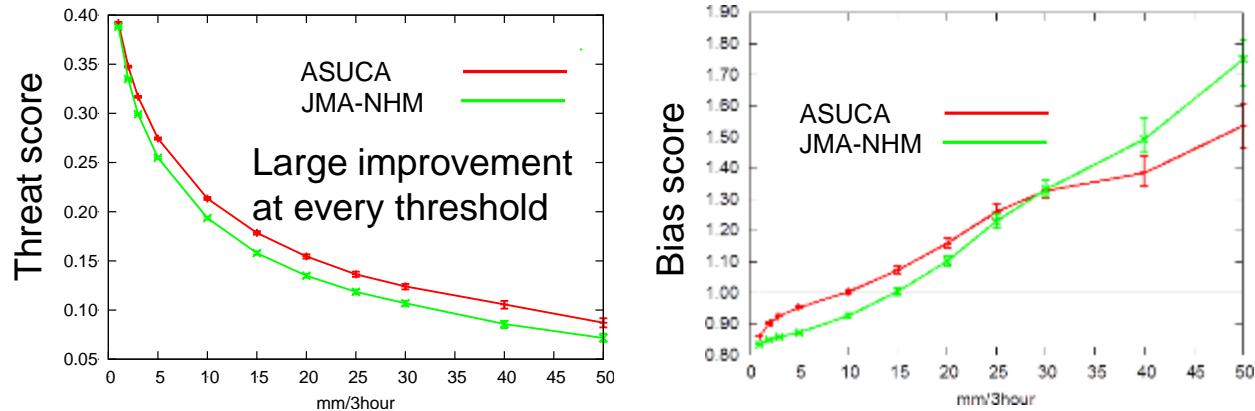

3h-accumulated precipitation at 18 Sep. 2016 03UTC.

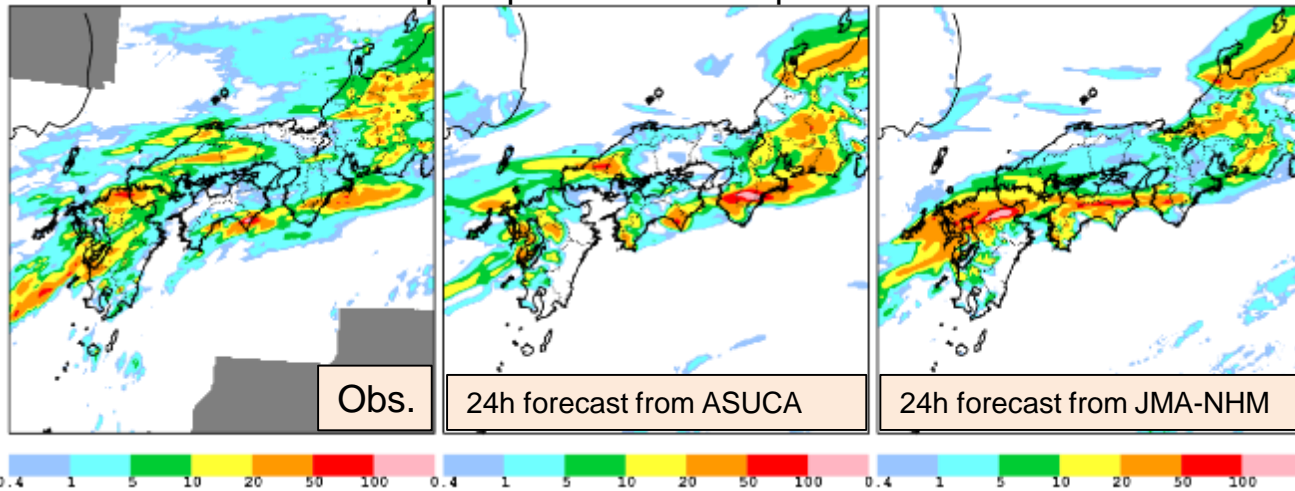

Score of MSM precipitation forecast

Threshold: 10mm/3hr, 2001.03–2020.10, FT00–15, verification grid spacing:20km

- :HPC Upgrade
- :Forecast model improvement
- :Introduction of new observation
- :DA system improvement
- :Improvement on observation data usage

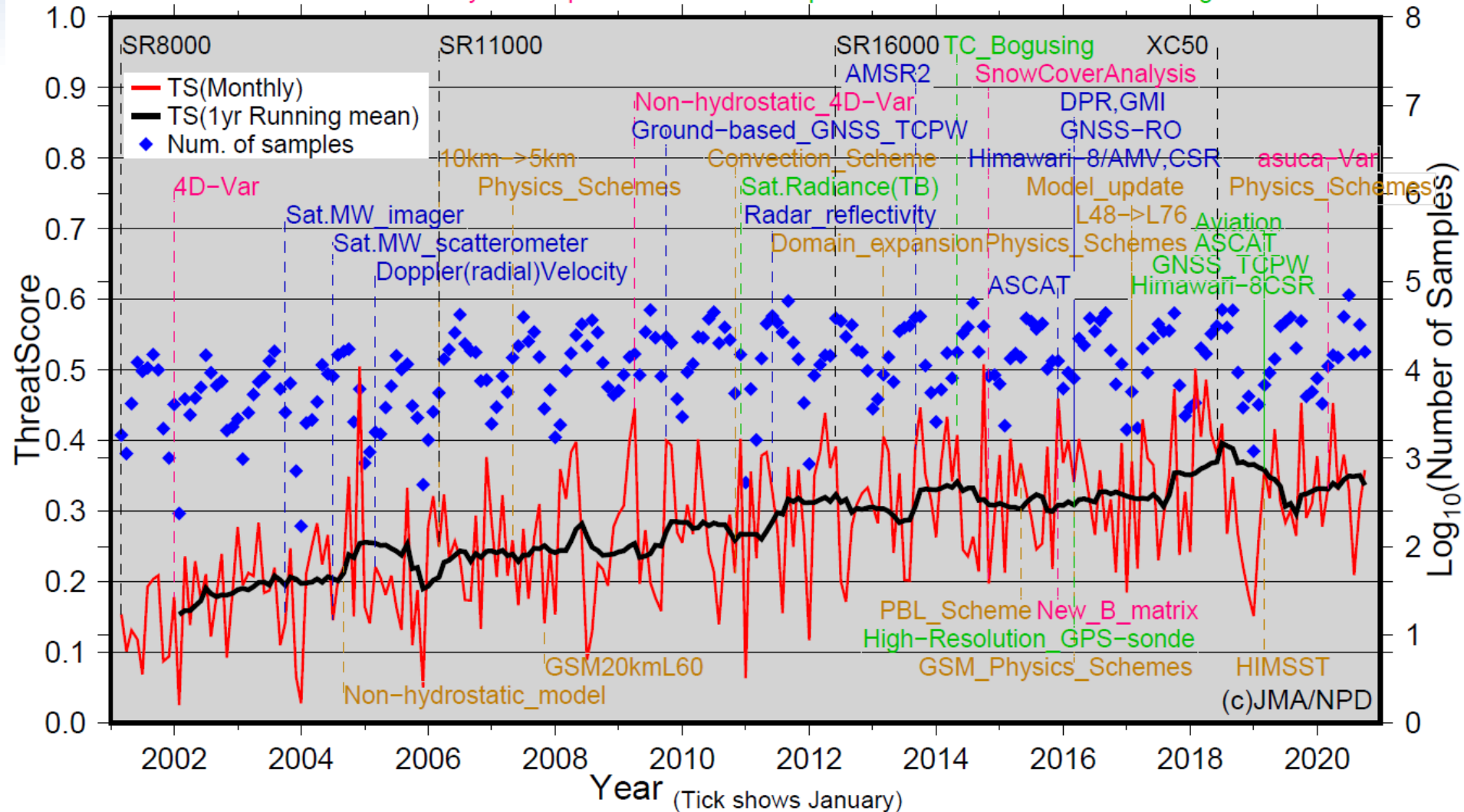

ASUCA Flowchart

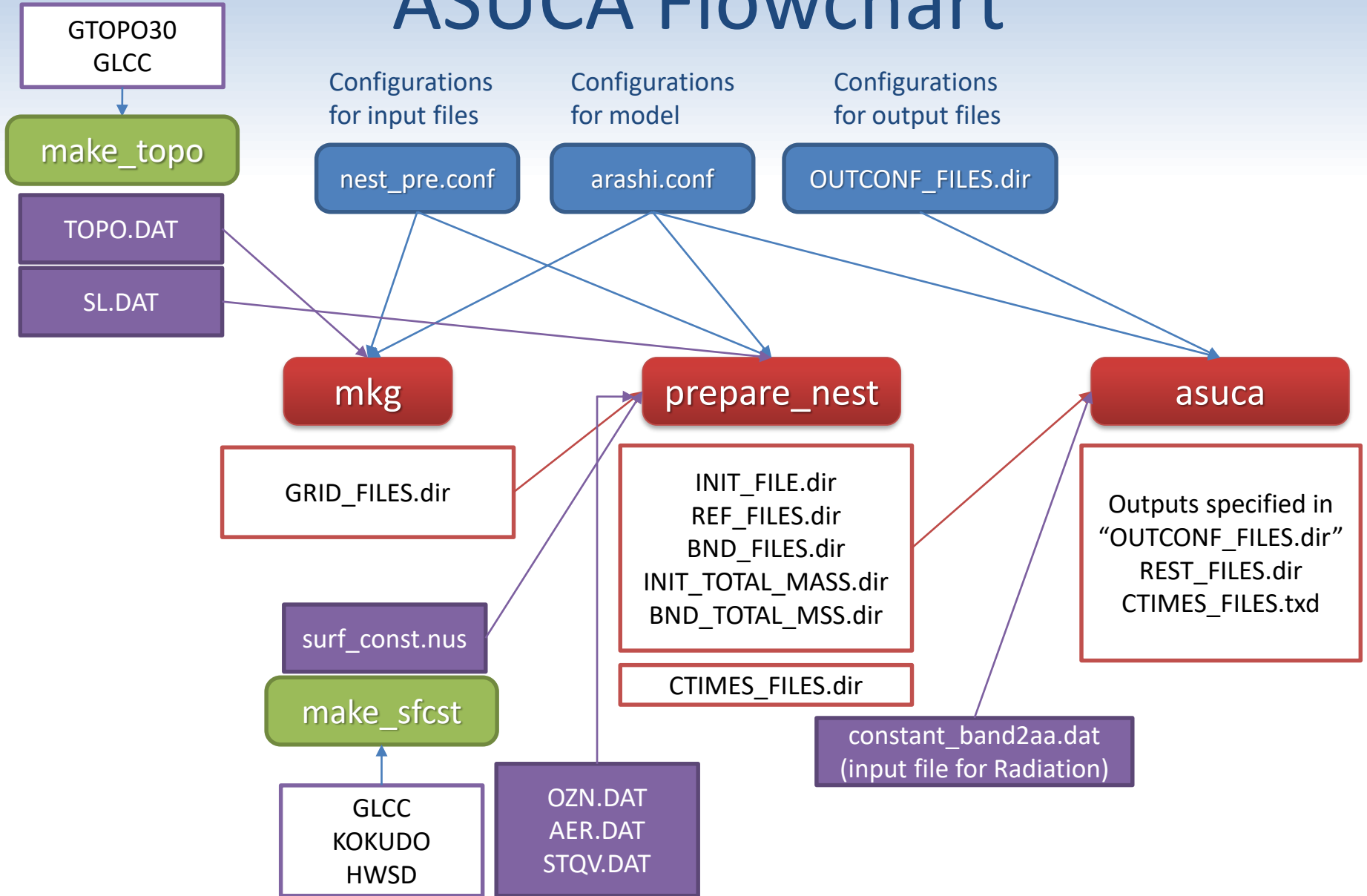

DATA ASSIMILATION SYSTEM: MESO-SCALE ANALYSIS (MA)

Data assimilation and forecast

First guess
(last forecast)

Data assimilation

NWP forecast

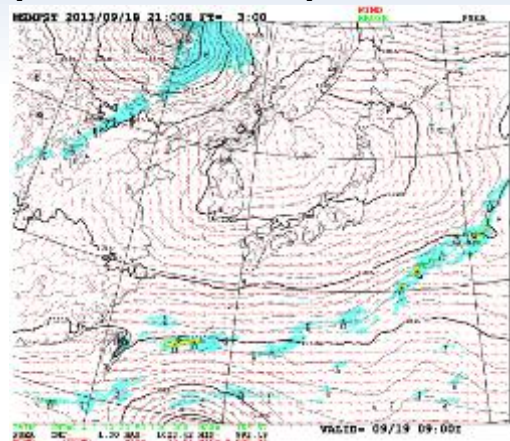

Initial condition

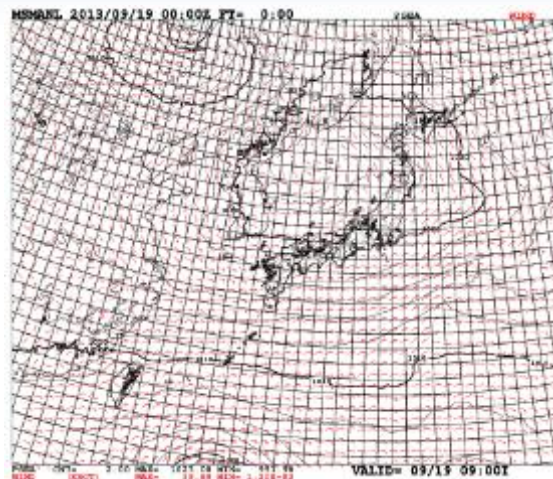

Next forecast

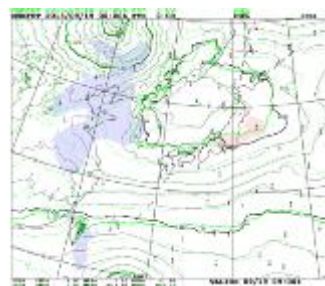
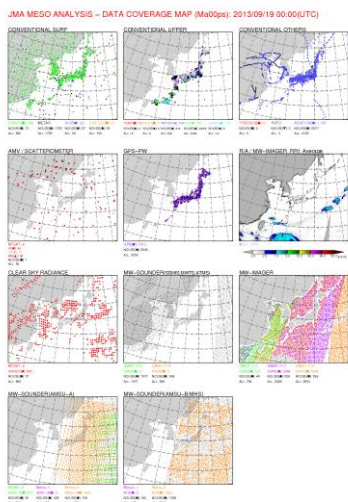
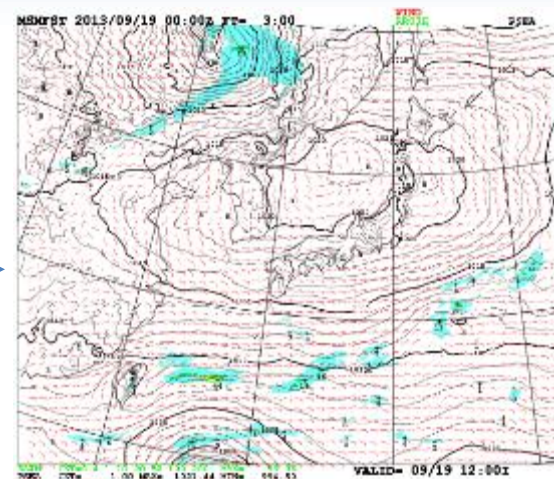

Increment

- The given model state (the first guess) is corrected by assimilating various observations
- Constraint is applied to keep consistency with the NWP model
- The analysis-forecast cycle uses forecast from the latest MA result as the first guess

Various observations

Four Dimensional Variational (4D-Var) Data Assimilation

- Minimize the cost function -> **Analysis**

$$J = \frac{1}{2} (\mathbf{x} - \mathbf{x}_B)^T \mathbf{B}^{-1} (\mathbf{x} - \mathbf{x}_B) + \frac{1}{2} (\mathbf{y} - \mathcal{H}\mathcal{M}(\mathbf{x}))^T \mathbf{R}^{-1} (\mathbf{y} - \mathcal{H}\mathcal{M}(\mathbf{x})) + J_P$$

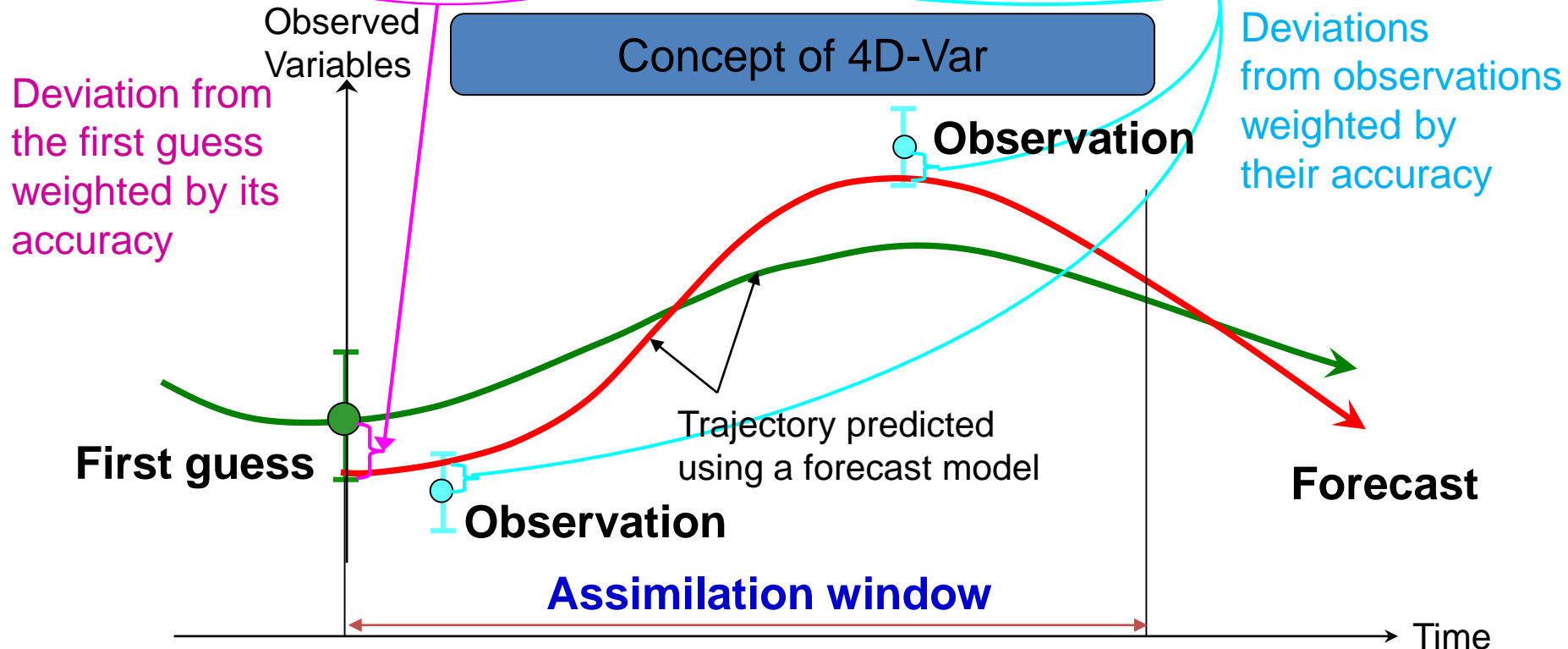

Analysis-Forecast cycle

- Iterate data assimilations and short term forecasts in turn, keeping the accuracy of initial conditions

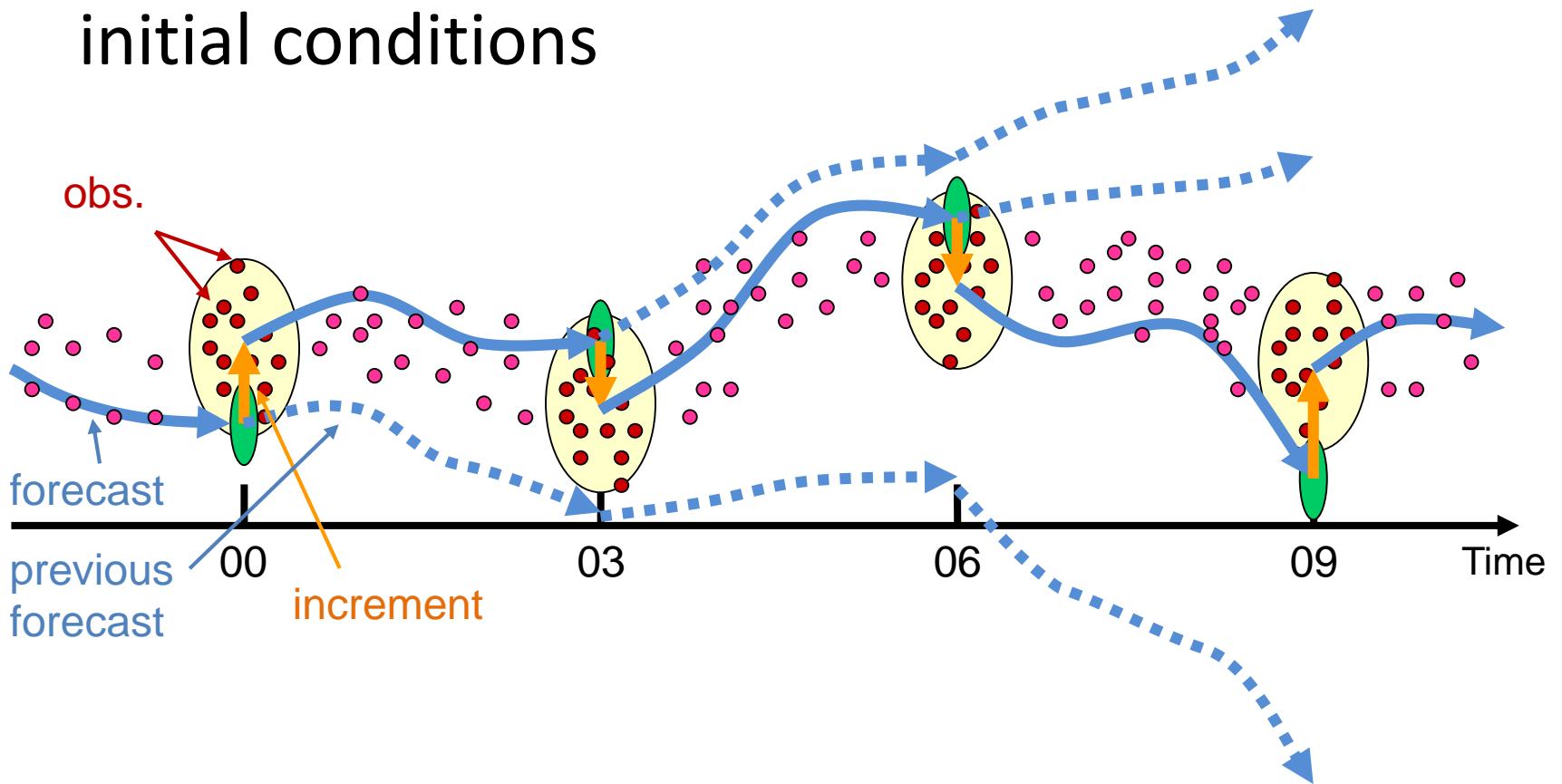

Observations assimilated to initialize JMA operational forecast models

		Global Analysis	Mesoscale Analysis	Local Analysis	Hourly Analysis
Direct Observations	Land Surface Observations	Ps, T, UV, RH		Ps, T, UV, RH	
	Automated Weather Stations			T, UV	
	Sea Surface Observations	Ps, T, UV, RH		Ps	
	Aircraft Observations	T, UV			
	Upper Air Sounding	Ps, T, UV, RH			
	Upper Air Wind Profiles	UV			
Remote Sensing	Wind Profiler	UV			
	Doppler Radar		Radial Velocity	Radial Velocity	
	Radar/Raingauge Analyzed Precipitation		RR		
	Ground-Based GNSS	ZTD	TPW	TPW	
Bogus	Typhoon Bogus	Ps, UV			
GEO Satellites	Atmospheric Motion Vector	UV			
	Clear Sky Radiance	Radiation			
LEO Satellites	Polar Atmospheric Motion Vector	UV			
	Microwave Sounder	Radiation			
	Infrared Sounder	Radiation			
	Microwave Imager	Radiation	Radiation, RR		Radiation
					Soil Moisture Content
	Scatterometer	UV			
					Soil Moisture Content
GNSS Radio Occultation	Bending Angle	Refractivity			
Radar / Lidar		RH			
LEO/GEO composit image	LEO GEO Winds	UV			

(As of 26th Sep. 2018)

Blue: Used in Surface Analysis

- Remote sensing data are used as important sources of detailed information for forecasting high impact events
- Satellite data contribute to improve NWP with their large coverage including less observed ocean regions

Upgrade Mesoscale Analysis

- In March 2020, a **4D-Var system based on ASUCA (asuca-Var)** was newly implemented in mesoscale analysis (MA), replacing the JMA-NHM-based 4DVar system (JNoVA; Honda et al. 2005).
- This upgrade contributes to more consistent mesoscale NWP system.

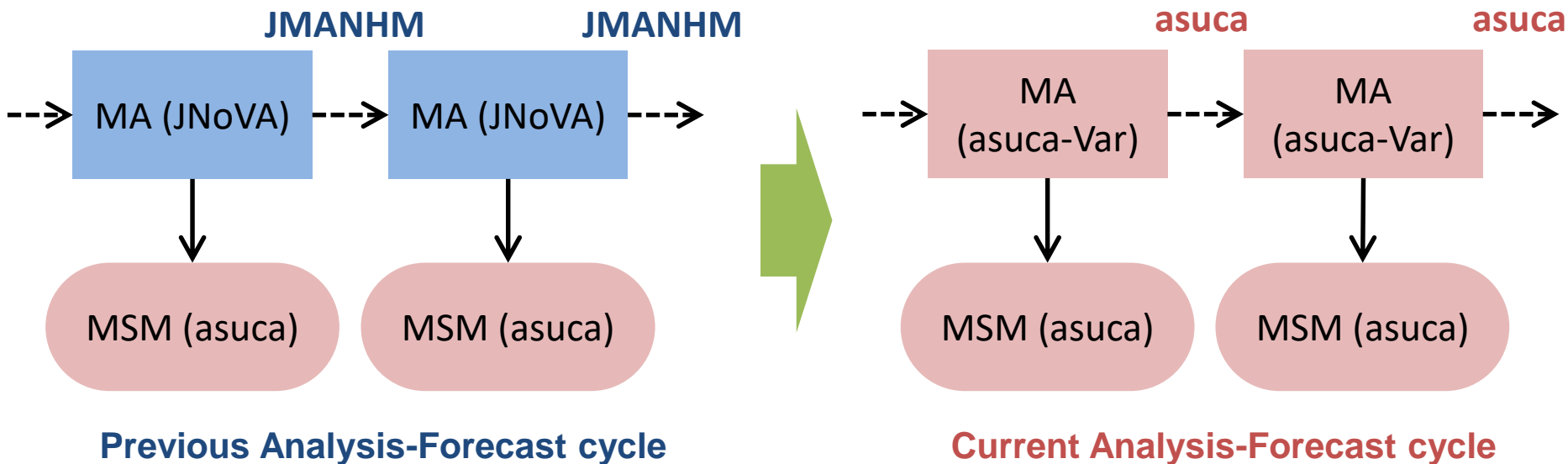

asuca-Var

asuca-Var: Variational data assimilation system based on ASUCA

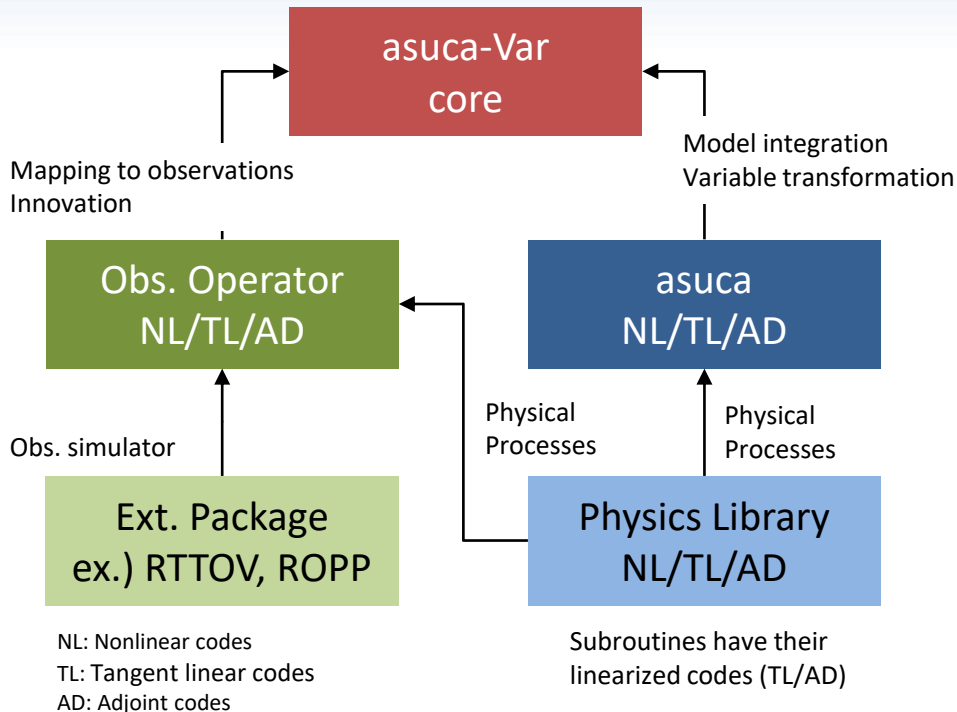

Schematic diagram of asuca-Var

Cost function

$$\begin{aligned}
 J = & \frac{1}{2} (\mathbf{x} - \mathbf{x}^b)^T \mathbf{B}_0^{-1} (\mathbf{x} - \mathbf{x}^b) \\
 & + \frac{1}{2} \sum_{i=0}^N (\mathcal{H}_i^{hr}(\mathbf{x}) - \mathbf{y}_i + \mathcal{P}(\mathbf{b}))^T \mathbf{R}_i^{-1} (\mathcal{H}_i^{hr}(\mathbf{x}) - \mathbf{y}_i + \mathcal{P}(\mathbf{b})) \\
 & + \frac{1}{2} (\mathbf{b} - \mathbf{b}^b)^T \mathbf{B}_{vbc}^{-1} (\mathbf{b} - \mathbf{b}^b) \\
 & + \frac{1}{2} (\mathbf{x}_{N/2} - \langle \mathbf{x}_{N/2} \rangle_{D.F.})^T \mathbf{B}_{D.F.}^{-1} (\mathbf{x}_{N/2} - \langle \mathbf{x}_{N/2} \rangle_{D.F.})
 \end{aligned}$$

Analysis

$$\mathbf{x}_{-3}^a = \min_x J(\mathbf{x}, \mathbf{x}^b, \mathbf{y})$$

$$\mathbf{x}_0^a = \mathcal{M}_{-3,0}^{hr}(\mathbf{x}_{-3}^a)$$

- asuca-Var core:** Core of the variational data assimilation
- asuca:** Forecast model including tangent linear and its adjoint models
- Obs. Operator:** Calculate observation vector from the model state variables
- Physics Library:** Physics process package used in asuca and Obs. Operator

Main updates of MA (1/2)

- **Introduction of variational bias correction (VARBC) technique**

- Adaptively estimate bias correction coefficients of satellite radiance data in variational data assimilation.
- In the previous MA, VARBC was not implemented, and bias correction coefficients from global analysis were used, resulting in an asymmetric distribution.
- In the current MA, the bias is properly corrected and the O-B shows a symmetric distribution.

Histogram of O-B (GPM/GMI)

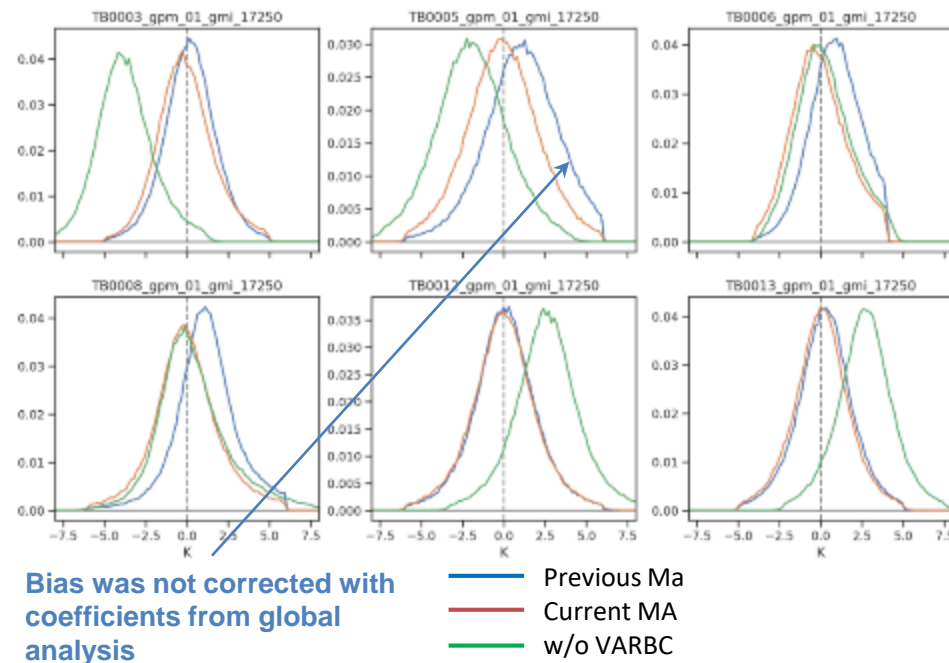

With VARBC, satellite radiance data are assimilated more appropriately.

Main updates of MA (2/2)

- **Change inner model configurations**
 - Within the inner loop for minimizing the cost function, tangent linear model is used as a forward operator in order to stabilize the minimization process.
 - During the minimization procedure (increase from 35 to 50 times), the basic field is updated (2 times) by the nonlinear model to obtain more optimal analyses.

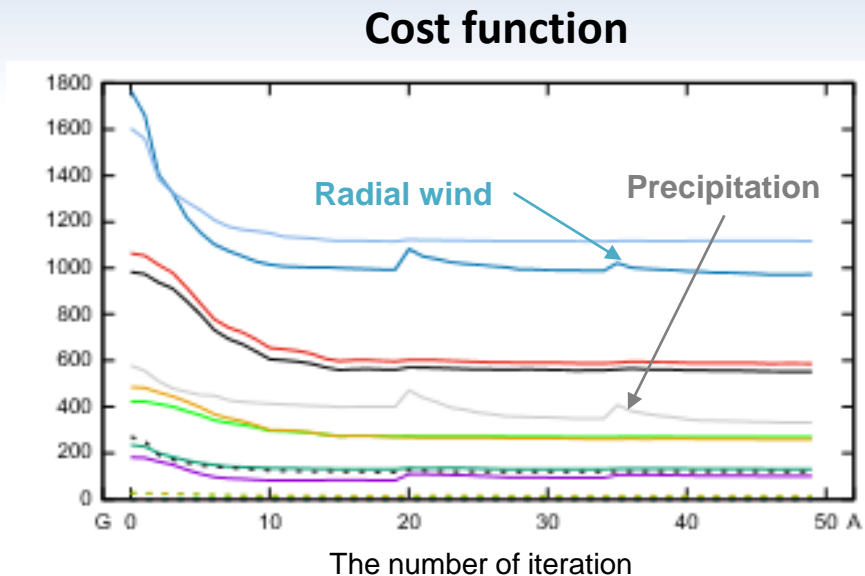

The basic fields is updated just after 20th and 35th iterations. Along with the updates, values of observation term becomes smaller, especially for radial wind and precipitation.

Impacts of the new MA

- The new MA significantly reduces the spin-up problem observed in the previous version.
 - Leading to the consistent mesoscale NWP system

Verification of surface temperature forecasts

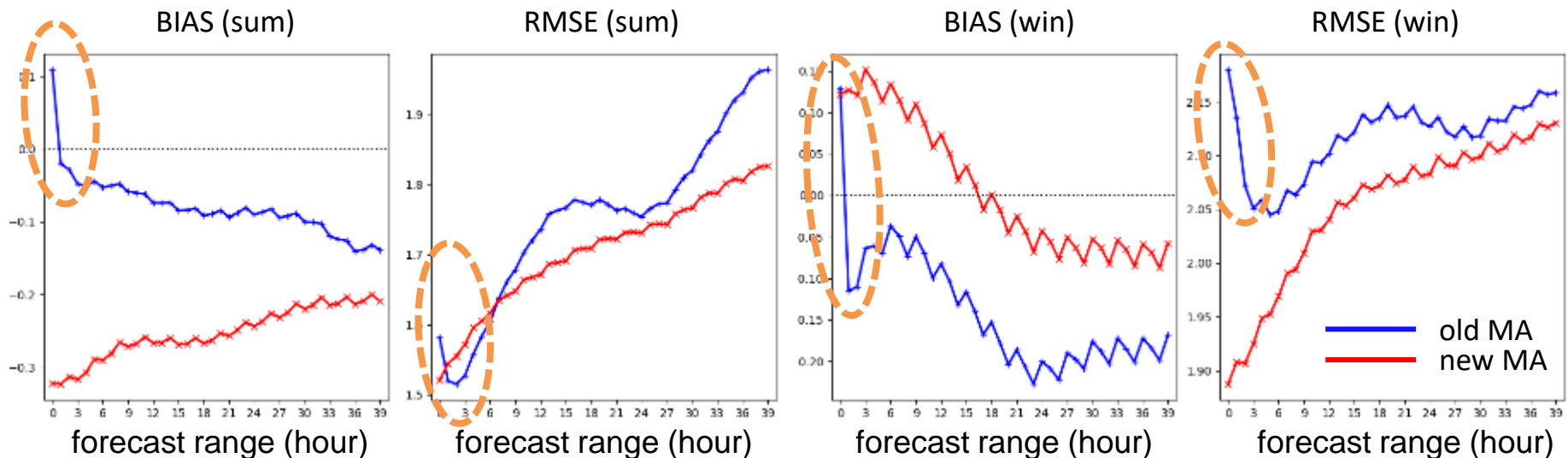

Surface temperature forecast skill is improved as well as the model spin-up is reduced.

MESO-SCALE ENSEMBLE PREDICTION SYSTEM (MEPS)

Ensemble prediction systems

NWP can contain uncertainties arising from imperfect initial conditions, model realization, etc.

⇒ Ensemble Prediction System (EPS) estimates uncertainties in NWP with multiple NWP runs using slightly different initial conditions and/or model settings, etc.

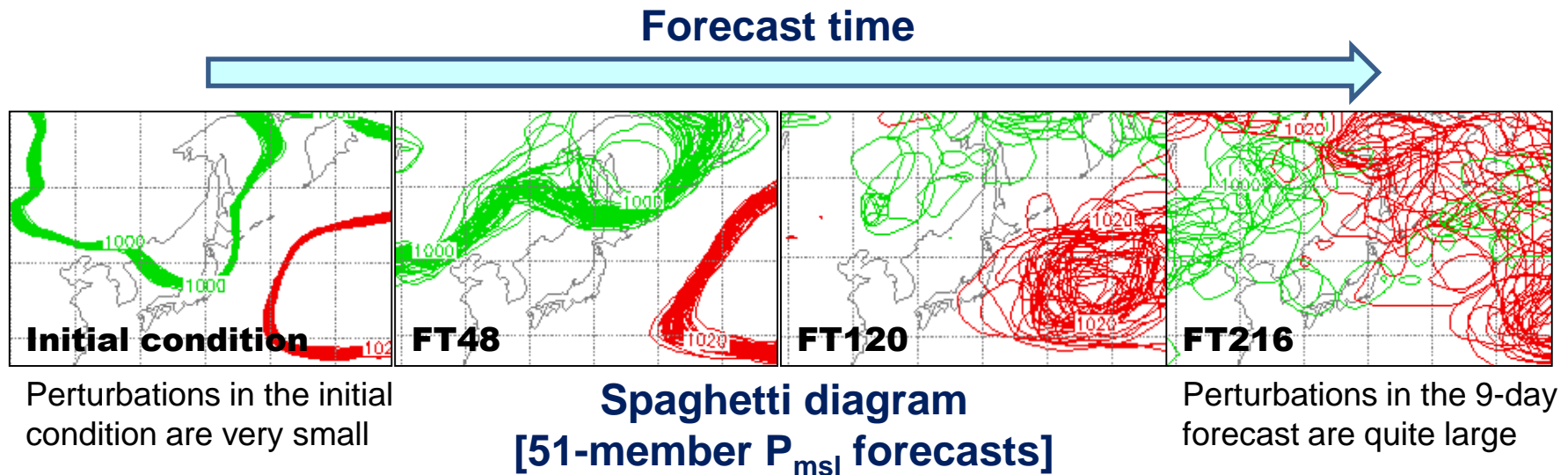

Mesoscale EPS in JMA

MEPS (**M**esoscale **E**nsemble **P**rediction **S**ystem) has been in operation since June 2019.

Specifications	
Forecast model	asuca (same as MSM)
Grid spacing	5 km x 5 km
Forecast domain	Same as MSM 
Forecast range	39 hours
# of member	21 (including an unperturbed run)
Frequency	4 times a day (00, 06, 12, 18 UTC)
Perturbations	Initial and lateral boundary conditions

Initial and boundary perturbations in MEPS

- **Singular vectors (SVs)** are employed to generate both initial and boundary perturbations.
- Amplification of SVs is measured with a **Total Energy norm**.
- As for initial perturbations, three types of SVs with different spatial and temporal resolutions are blended.

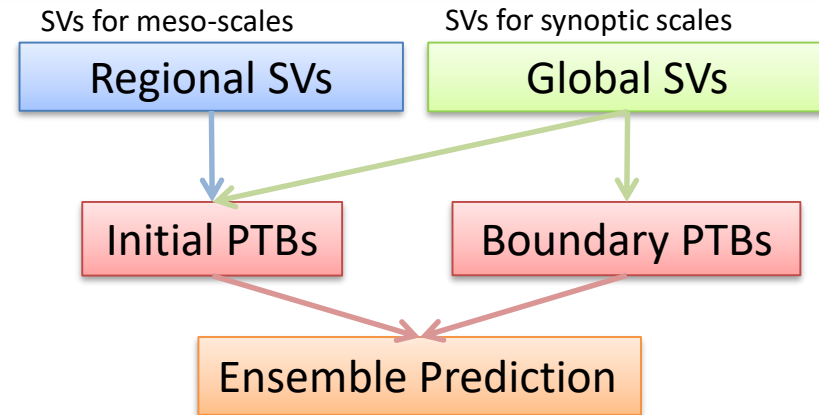

Schematic diagram of MEPS
(Model uncertainties are not considered)

Regional SVs are expensive but effective to capture uncertainties in mesoscale NWP, especially for heavy rainfalls (Ono et al. 2020).

MEPS estimates uncertainties

MSM

- Large TC track error leads underestimation of precipitation.
- Better with shorter lead times.

Worst-case scenario & POP

- Heavy rainfall is successfully captured, **even with longer lead times.**

Observation
2018.10.01 00UTC

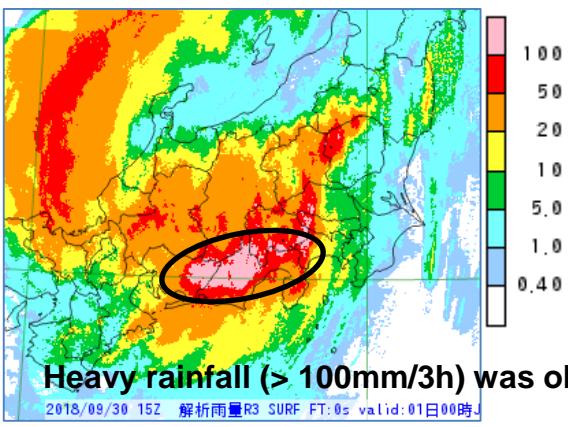

3-hour accumulated prep.

MSM

Maximum (Worst-case scenario)

POP (> 100 mm/ 3h)

2018.09.29
00 UTC INIT
T = 39

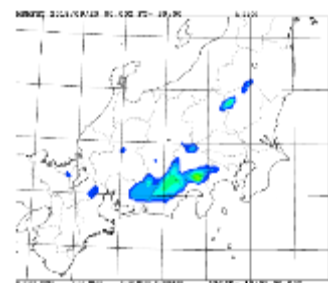
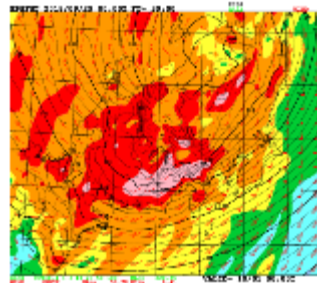
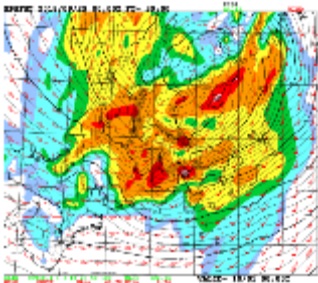

2018.09.29
06 UTC INIT
T = 33

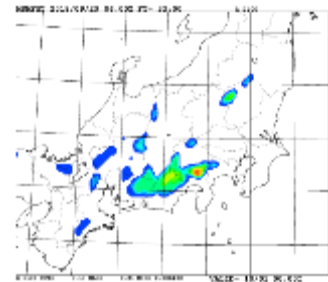
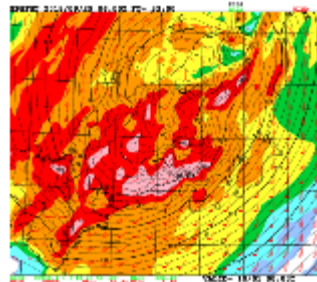
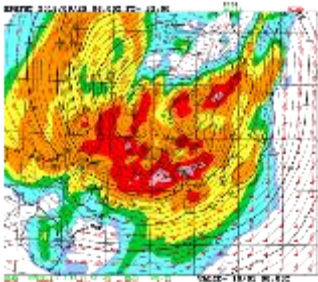

2018.09.29
12 UTC INIT
T = 27

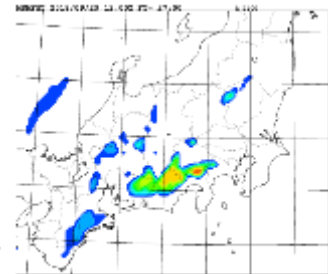
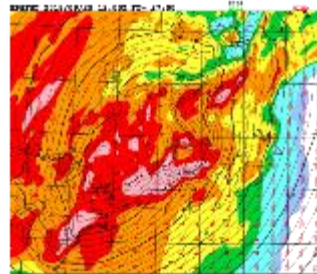
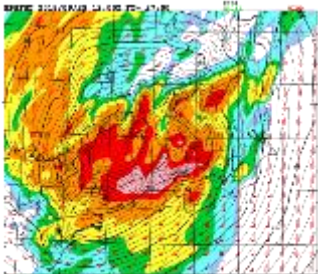

2018.09.29
18 UTC INIT
T = 21

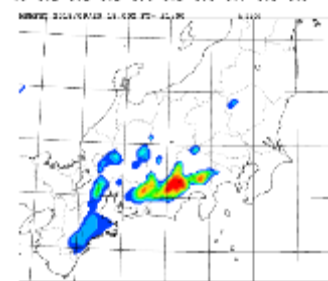
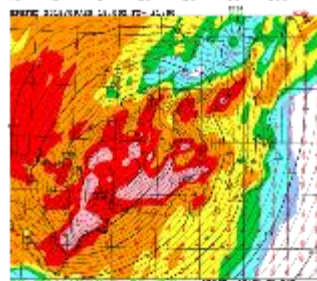
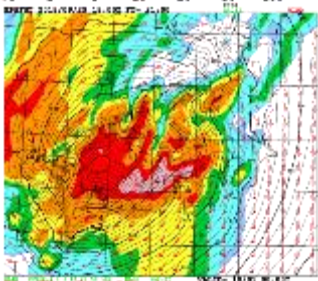

Shorter leads

2018.09.29 00 UTC INIT T=39

Precipitation forecast of each ensemble member

MSM

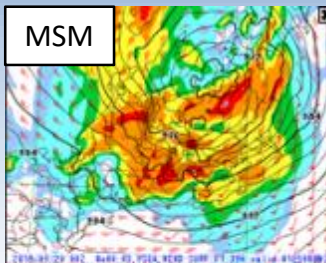

Observation

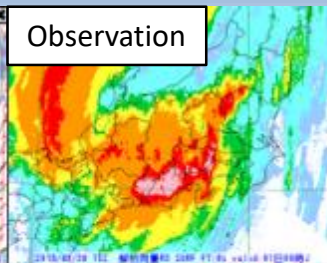

MSM: The predicted TC moved faster than the observation.
MEPS: Some ensemble members successfully captured heavy rainfall along with the better TC track forecast.

MEPS 20 perturbed members

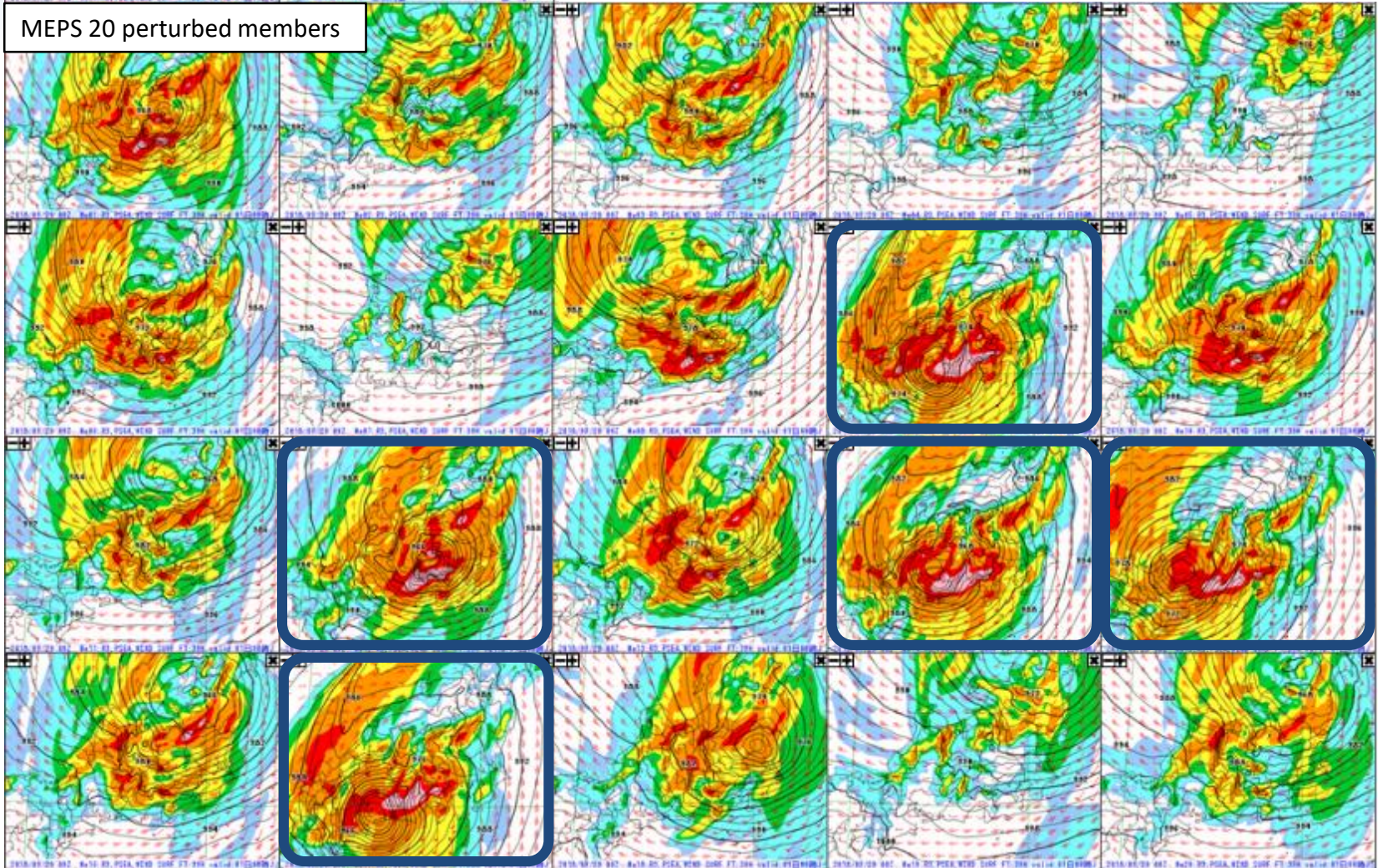

mm



Summary

- JMA's meso-scale NWP system is introduced.
 - MSM has adopted **ASUCA** since February 2017.
 - ASUCA is developed aiming at;
 - Higher accuracy, stability
 - Exclusion of artificial parameters
 - Higher efficiency on massive parallel scalar multi-core architecture
 - Keeping the codes as modular as possible
 - ASUCA-based 4DVar has been implemented in operational Meso-scale analysis since March 2020.
 - Mesoscale ensemble prediction system has been in operation since June 2019.

References

- Hara, T., K. Kawano, K. Aranami, Y. Kitamura, M. Sakamoto, H. Kusabiraki, C. Muroi, and J. Ishida, 2012: Development of Physics Library and its application to ASUCA. *CAS/JSC WGNE Res. Activ. Atmos. Oceanic Modell.*, **42**, 05.05–05.06.
- Honda, Y., M. Nishijima, K. Koizumi, Y. Ohta, K. Tamiya, T. Kawabata, and T. Tsuyuki, 2005: A pre-operational variational data assimilation system for a non-hydrostatic model at the Japan Meteorological Agency: Formulation and preliminary results. *Quart. J. Roy. Meteor. Soc.*, **131**, 3465–3475.
- Ishida, J., C. Muroi, and Y. Aikawa, 2009: Development of a new dynamical core for the nonhydrostatic model. *CAS/JSC WGNE Res. Activ. Atmos. Oceanic Modell.*, **39**, 05.09–05.10.
- Ishida, J., C. Muroi, K. Kawano, and Y. Kitamura, 2010: Development of a new nonhydrostatic model “ASUCA” at JMA. *CAS/JSC WGNE Res. Activ. Atmos. Oceanic Modell.*, **40**, 05.11–05.12.
- JMA, 2019: Outline of the operational numerical weather prediction at the Japan Meteorological Agency, available at: <https://www.jma.go.jp/jma/jma-eng/jma-center/nwp/outline2019-nwp/index.htm>
- Ono, K., M. Kunii, and Y. Honda, 2020: The regional model-based Mesoscale Ensemble Prediction System, MEPS, at the Japan Meteorological Agency. *Quart. J. Roy. Meteor. Soc.* (in press)
- Saito, K., T. Fujita, Y. Yamada, J. Ishida, Y. Kumagai, K. Aranami, S. Ohmori, R. Nagasawa, S. Kumagai, C. Muroi, T. Kato, H. Eito, and Y. Yamazaki, 2006: The operational JMA Nonhydrostatic Mesoscale Model. *Mon. Wea. Rev.*, **134**, 1266–1298.
- Saito, K., J. Ishida, K. Aranami, T. Hara, T. Segawa, M. Narita, and Y. Honda, 2007: Nonhydrostatic Atmospheric Models and Operational Development at JMA. *J. Meteor. Soc. Japan*, **85B**, 271–304.